

 **PACIFIC OUTDOOR**
PRODUCTS, INC.

PRODUCT CATALOG



WWW.PACIFICOUTDOOR.COM

PROUDLY MADE IN THE U.S.A.

TABLE OF CONTENTS



4-14 POLY PLAYSYSTEMS



15 OTHER FUN PLAY EQUIPMENT



16-17 SWING SETS



18-20 STEEL TABLES & BENCHES



20-23 POLY TABLES & BENCHES



24 BIKE RACKS



25-45 STAYFIT OUTDOOR FITNESS



46-53 SUPERMAX SYSTEMS



54-56 DOGGIE PLAYSYSTEMS

WWW.PACIFICOUTDOOR.COM

PROUDLY MADE IN THE U.S.A. MAPLE VALLEY, WA 425-432-6000

HAND-BUILT QUALITY + OUTSTANDING CUSTOMER SERVICE

=

THE PERFECT PRODUCT

For over 43 years, Pacific Outdoor Products has been committed to designing, engineering, and manufacturing state of the art playground equipment, outdoor fitness equipment, dog park equipment, and site furnishings. All our products are proudly made in the USA and manufactured in Maple Valley, Washington. Pacific Outdoor Products offers pride of workmanship, innovative design, and superior customer service; resulting in the highest quality products and user experience.

PLAYGROUND EQUIPMENT

All our commercial playground equipment is manufactured using 4×6, 6×6 and 5/4×6 recycled HDPE plastic. Created by our in-house design team, these completely modular playgrounds can be custom designed to fit any budget, area, and age group! Pacific Outdoor Products provides playsets that are packed full of traditional physical activities that challenge children's abilities, build strength, improve coordination, enhance balance, and promote cardiovascular heart-healthy exercise along with social interaction. Your Poly Playsystem will challenge children to master different climbing activities and overhead tasks; building muscle strength and endurance all the while appealing to a child's imagination!



HAND MADE TO ORDER BY EXPERT CRAFTSMAN

“Hand Made to Order” manufacturing means each order is hand-built when the order is placed! No assembly line production or imported products; all components are made in the USA from the finest materials. This guarantees our equipment is built right the first time and that parts will always be available. Every piece of equipment is double-checked and hand-welded out of the heaviest and strongest materials for a custom fit. As a customer, you should expect, and will receive, nothing less. Look through our catalog and imagine the possibilities. Let Pacific Outdoor Products turn your vision into reality!

EVERYTHING CAN BE CUSTOMIZED... TO FIT YOUR BUDGET AND AGE GROUP!

Poly Playsystems is the most modular playground system available. You will not find a more design friendly playground than Poly Playsystems. Your Poly Playsystem will be easy to install, as all holes are predrilled and countersunk for safety and all components and parts are included and ready for assembly. Just contact us, and we will design a playset that will fit your budget, age group, and area. Your playset will be a sound investment and a permanent component to your playground as it will never need to be replaced.

FAMILY OWNED
SINCE 1980



Easy to install, all holes pre-drilled to easily bolt together.

Vertical beams are hand-routed and hand-drilled for proper fit and finish.

Steel components are welded, fitted and powder coated for maximum strength and durability.

Walls, activities, climbers and end ladders are engineered for strength and endurance.

Custom one-piece welded deck frames are super strong and eliminate deck sagging.

Slides, roofs and panels are heavy duty rotational molded plastic for longevity.



Poly Playsystems is the only recycled product available that uses a pre-drilled bolt-thru fastening system, rather than a weaker lag-bolt system. The result is the strongest recycled playset on the market. All vertical supports and attached activities are designed and engineered for optimal strength. Virtually maintenance free and graffiti resistant, Poly Playsystems is simply the best choice for your Playground needs.

PLAY GREEN!

MADE FROM **100%** RECYCLED PLASTIC

Recycled milk cartons were used to create this play structure



VISIT
WWW.PACIFICOUTDOOR.COM
FOR MORE!

THE BENEFITS OF PLASTIC LUMBER:

- 100% Waterproof
- Will not rot, splinter, corrode, mold or decay.
- UV-resistant- retains its color and luster for years.
- Economic benefits – low maintenance.
- Resistant to most chemical exposures
- Requires no painting or sealing.
- Graffiti resistant – cleans right up.
- Anti-Insect – termites and other insects won't find a home in your playset
- Will not rust, splinter, crack, or chip like steel or wood.
- Environmentally friendly, made from recycled materials.
- Greater impact resistance than wood.



POLY PLAYSYSTEMS



WWW.PACIFICOUTDOOR.COM



IMPORTANT
It is essential to provide and maintain a cushioning ground cover around and beneath all play structures.
IMPORTANT

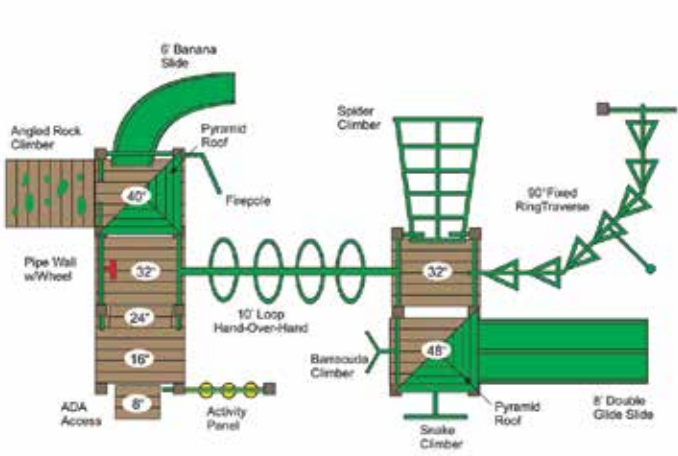

PE-7705

AREA 34' x 48'
CAPACITY 42 – 50 kids
AGE RANGE 5 – 12 years
ACTIVITIES 11

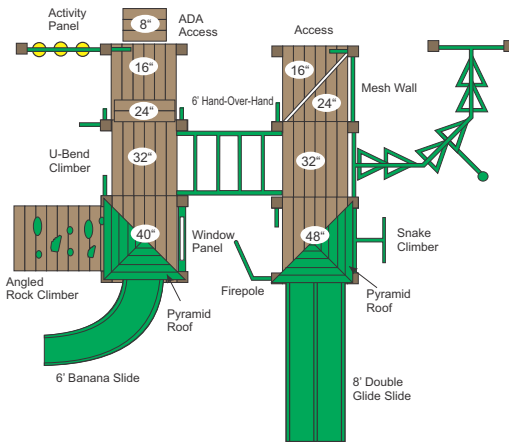

PE-7710

AREA 36' x 44'
CAPACITY 40 – 48 kids
AGE RANGE 5 – 12 years
ACTIVITIES 10

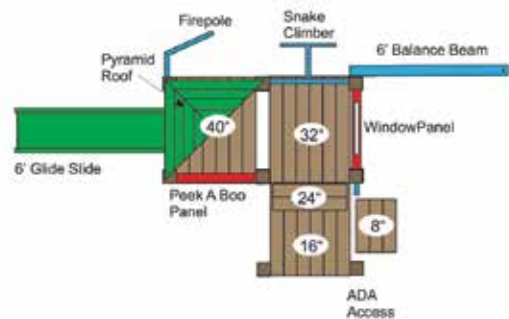

PE-7715

AREA 24' x 34'
CAPACITY 26 – 30 kids
AGE RANGE 2 – 12 years
ACTIVITIES 6

VISIT
WWW.PACIFICOUTDOOR.COM
FOR MORE!

PLAYSYSTEMS



PE-7722

AREA 50' x 56'
CAPACITY 75 – 90 kids
AGE RANGE 5 – 12 years
ACTIVITIES 17

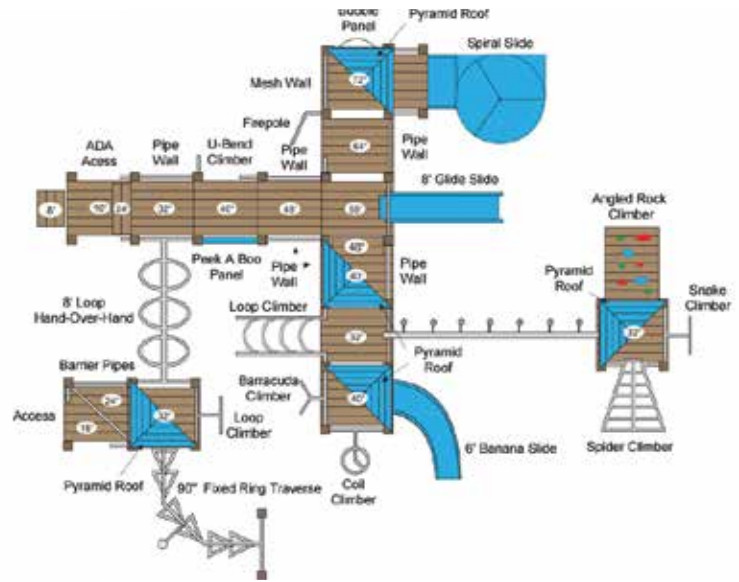

PE-7727

AREA 36' x 40'
CAPACITY 32 – 40 kids
AGE RANGE 5 – 12 years
ACTIVITIES 9

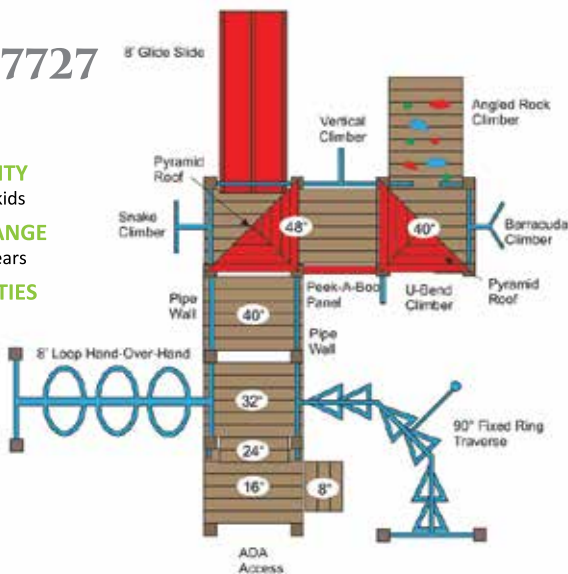

WWW.PACIFICOUTDOOR.COM

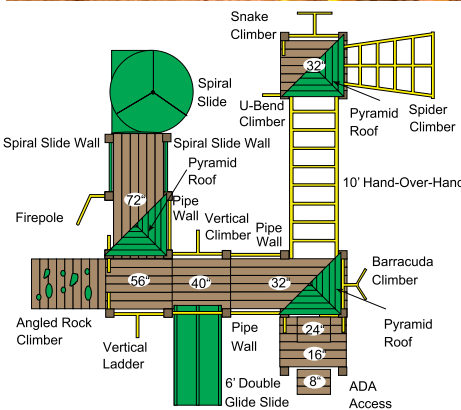

PE-7735

AREA	CAPACITY	AGE RANGE	ACTIVITIES
40' x 42'	54 - 68 kids	5 - 12 years	11

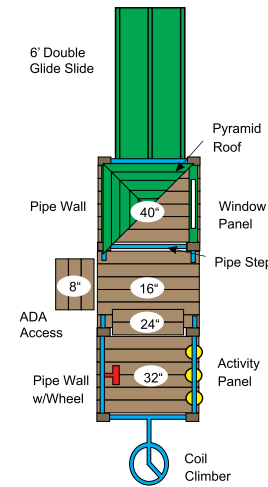

PE-7740

AREA	CAPACITY	AGE RANGE	ACTIVITIES
18' x 34'	18 - 24 kids ****	2 - 12 years	6

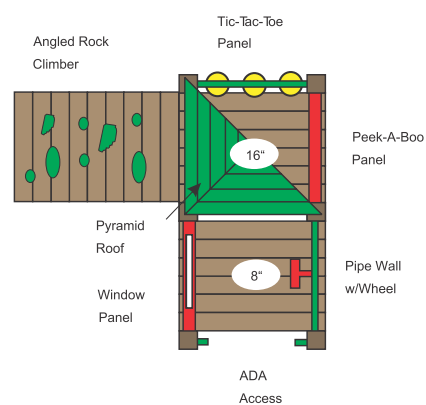

PE-7745

AREA	CAPACITY	AGE RANGE	ACTIVITIES
20' x 20'	10 - 14 kids	2 - 5 years	5

VISIT
WWW.PACIFICOUTDOOR.COM
 FOR MORE!



IMPORTANT
 It is essential to provide and maintain a cushioning ground cover around and beneath all play structures.
IMPORTANT

PLAYSYSTEMS

PE-7753

AREA 44' x 46'
CAPACITY 56 – 64 kids
AGE RANGE 5 – 12 years
ACTIVITIES 16

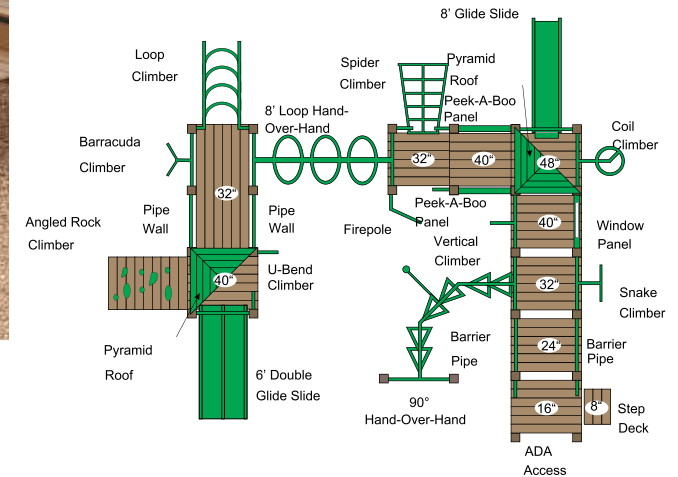

PE-7760

AREA 30' x 34'
CAPACITY 28 – 30 kids
AGE RANGE 5 – 12 years
ACTIVITIES 7

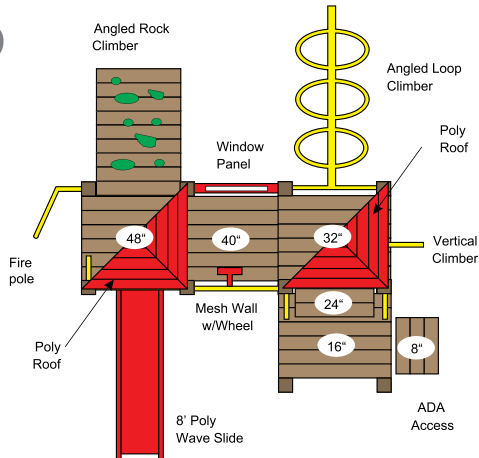

PE-7770

AREA 32' x 40'
CAPACITY 36 – 44 kids
AGE RANGE 5 – 12 years
ACTIVITIES 9

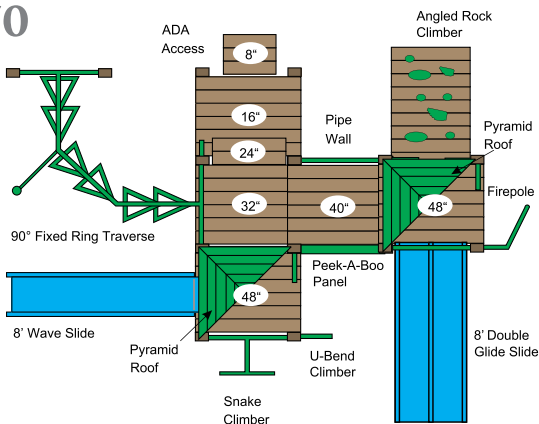

LIFETIME WARRANTY ON POLY UPRIGHTS

COMMERCIAL PLAYGROUNDS

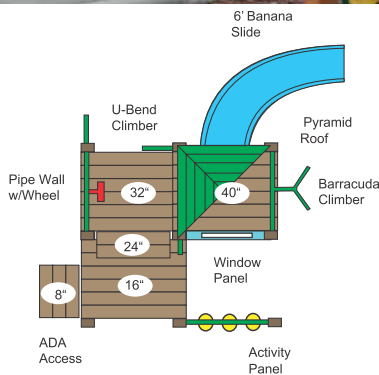

PE-7780

AREA 28' x 28'
CAPACITY 16 – 20 kids
AGE RANGE 2 – 12 years
ACTIVITIES 6

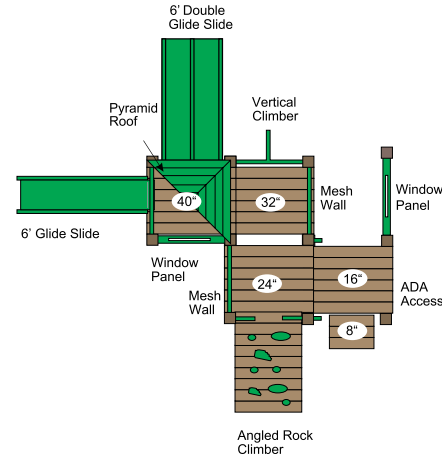

PE-7785

AREA 32' x 34'
CAPACITY 22 – 26 kids
AGE RANGE 5 – 12 years
ACTIVITIES 6

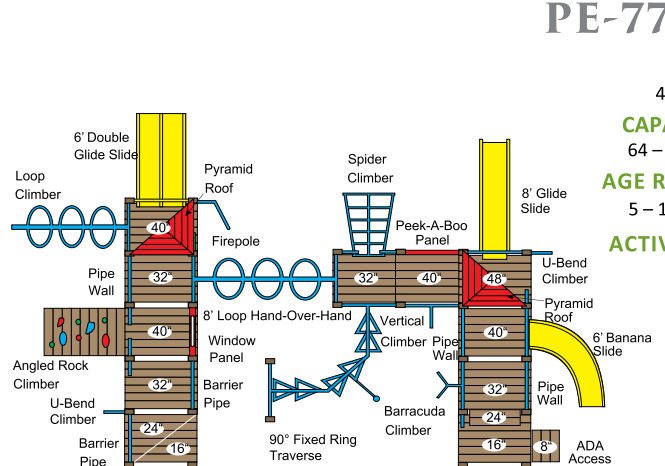

PE-7795

AREA 42' x 44'
CAPACITY 64 – 76 kids
AGE RANGE 5 – 12 years
ACTIVITIES 18



**FREE STANDING
NO HOLES TO DIG!**

IMPORTANT
It is essential to provide and maintain a cushioning ground cover around and beneath all play structures.
IMPORTANT

PLAYSYSTEMS

PE-7812

AREA 26' x 28' **CAPACITY** 12 – 14 kids **AGE RANGE** 5 – 12 years **ACTIVITIES** 6

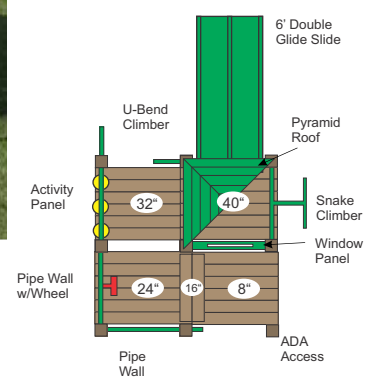

PE-7815

AREA 30' x 38'
CAPACITY 24 – 30 kids
AGE RANGE 5 – 12 years
ACTIVITIES 7

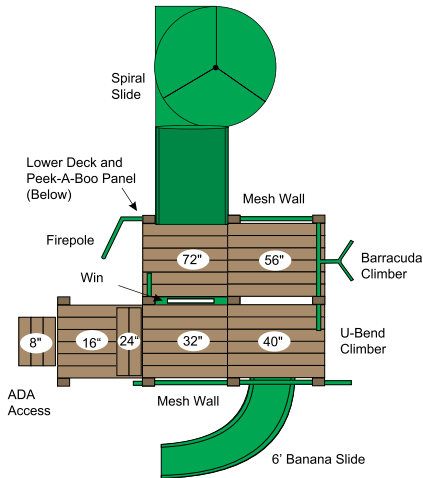

PE-7825

AREA 32' x 34'
CAPACITY 30 – 38 kids
AGE RANGE 5 – 12 years
ACTIVITIES 8

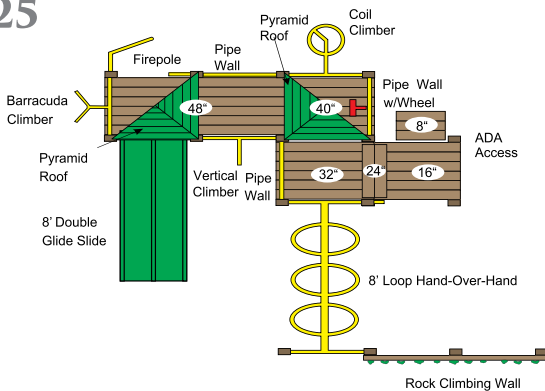

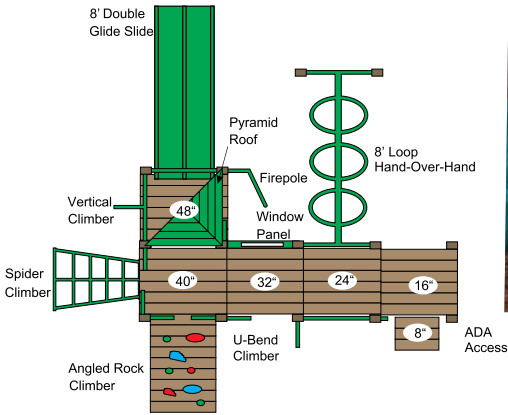

PE-7835

AREA 36' x 36'	CAPACITY 28 – 36 kids	AGE RANGE 5 – 12 years	ACTIVITIES 9
--------------------------	---------------------------------	----------------------------------	------------------------

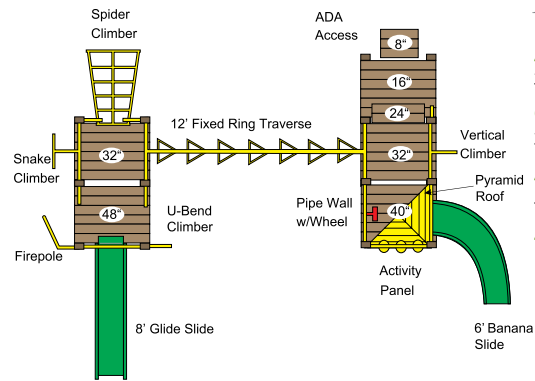

PE-7850

AREA 36' x 42'	CAPACITY 28 – 34 kids	AGE RANGE 5 – 12 years	ACTIVITIES 10
--------------------------	---------------------------------	----------------------------------	-------------------------

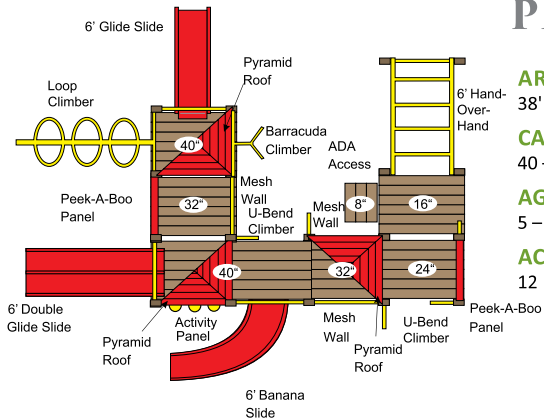

PE-7858

AREA 38' x 38'	CAPACITY 40 – 48 kids	AGE RANGE 5 – 12 years	ACTIVITIES 12
--------------------------	---------------------------------	----------------------------------	-------------------------

VISIT
WWW.PACIFICOUTDOOR.COM
FOR MORE!

PLAYSYSTEMS

IMPORTANT
 It is essential to provide and maintain a cushioning ground cover around and beneath all play structures.
IMPORTANT

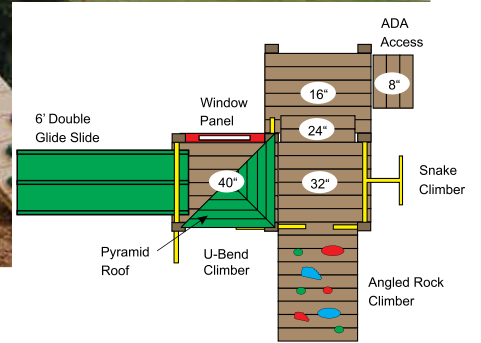

PE-7868

AREA 30' x 28'
CAPACITY 20 – 26 kids
AGE RANGE 5 – 12 years
ACTIVITIES 5

PE-7872

AREA 42' x 42'
CAPACITY 40 – 48 kids
AGE RANGE 5 – 12 years
ACTIVITIES 12

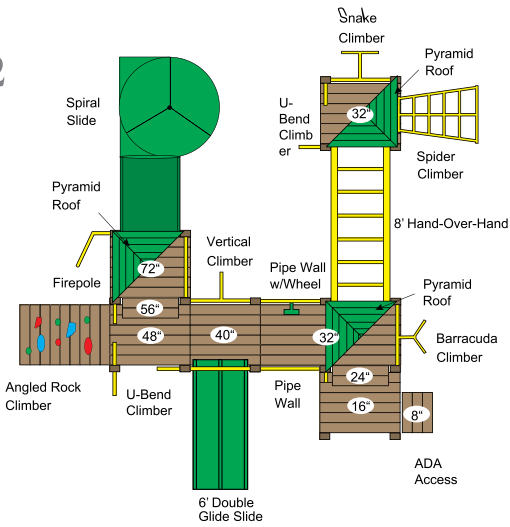

PE-7876

AREA 26' x 32'
CAPACITY 10 – 12 kids
AGE RANGE 5 – 12 years
ACTIVITIES 6

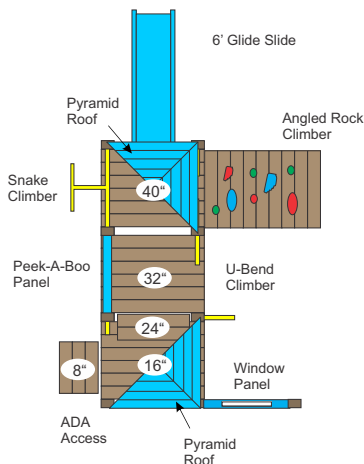

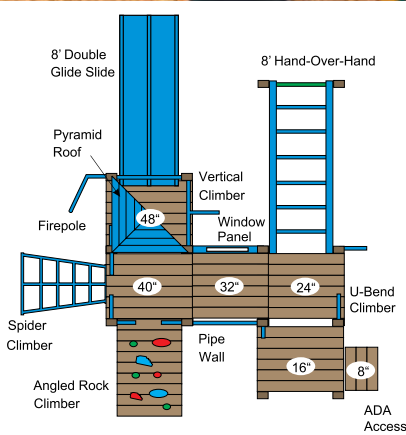

PE-7880

AREA	CAPACITY	AGE RANGE	ACTIVITIES
34' x 36'	32 – 40 kids	5 – 12 years	9

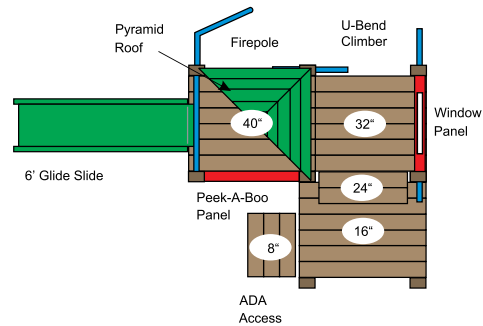

PE-7887

AREA	CAPACITY	AGE RANGE	ACTIVITIES
24' x 28'	12 – 16 kids	5 – 12 years	5

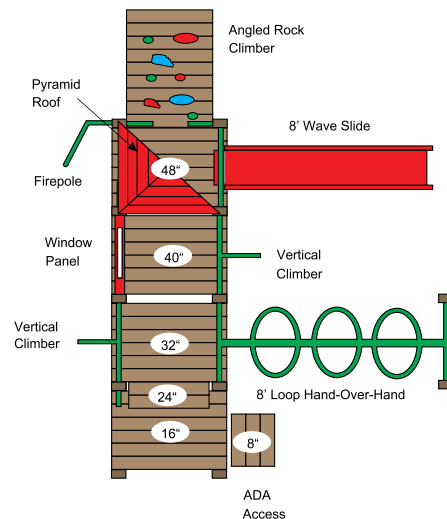

PE-7894

AREA	CAPACITY	AGE RANGE	ACTIVITIES
28' x 36'	18 – 26 kids	5 – 12 years	7

OTHER FUN PLAYGROUND EQUIPMENT

VISIT
WWW.PACIFICOUTDOOR.COM
FOR MORE!



SOCCER GOALS



BASKETBALL POLE



GT-50 BBQ GRILL



SPRING ANIMALS



PICKLE BALL POLES & NET



POLY ROCK CLIMBING WALL

Installation Type: In-Ground Mount
Available Sizes: Widths: 8', 12'
Heights: 8', 10'

OTHER FUN

PLAYGROUND SWINGS

We offer a variety of swings for all ages! Our swings are perfect for school playgrounds, parks, churches, homeowner's associations or any area that requires a heavy duty swing set. From traditional belt seats to baby buckets Pacific Outdoor Products can accommodate all ages. Choose the swing style to meet your needs then add belt seats, baby buckets or a tire swing.



PE-2034 HEIGHT 8' AREA 30' x 32' MATERIALS Steel FINISH Powder Coated



PE-2030 HEIGHT 8' AREA 24' x 32' MATERIALS Steel FINISH Powder Coated



PE-2028 HEIGHT 8' AREA 38' x 32' MATERIALS Steel FINISH Powder Coated



PE-2024 HEIGHT 8' AREA 30' x 32' MATERIALS Steel FINISH Powder Coated



PE-2026 HEIGHT 8' AREA 44' x 32' MATERIALS Steel FINISH Powder Coated



PE-2050 HEIGHT 7' AREA 32' x 28' MATERIALS Steel FINISH Powder Coated



VISIT
WWW.PACIFICOUTDOOR.COM
FOR MORE!

SITE FURNISHINGS

SITE FURNISHINGS

For over 43 years, Pacific Outdoor Products has been manufacturing a wide variety of heavy-duty outdoor site furnishings. The equipment includes all steel hand-welded, hand-fitted tables, benches, trash receptacles and bike racks, or choose our heavy duty or super duty welded steel frames with HDPE recycled plastic tops and seats.

The recycled plastic table frames are engineered so the poly tops and seats will not warp or sag. The site furnishings are all hand fitted, welded and powder coated to assure a consistent quality that will perform for years to come. They are all available for surface mount or in-ground installation, custom colors are available.

STEEL TABLES



SE-5320 STEEL FOUR-SIDED TABLE

Contemporary 4 seat steel strap table. The ADA version includes three seats to accommodate wheelchair access. Finish is powder coated. Surface or in-ground mount.

Installation Type:
In-Ground Mount, Surface Mount

Finish Type:
Powder Coat



SE-5325 6FT STEEL TABLE

Contemporary 2 seat steel strap table. The ADA version includes a longer top to accommodate wheelchair access. Finish is powder coated. Surface or in-ground mount.

Installation Type:
In-Ground Mount, Surface Mount

Finish Type:
Powder Coat

AVAILABLE STEEL COLORS:

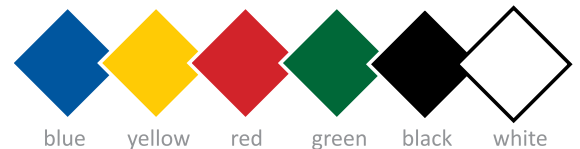

blue yellow red green black white

STEEL BENCHES

Contemporary 2 seat steel strap table. The ADA version includes a longer top to accommodate wheelchair access. Finish is powder coated. Surface or in-ground mount.

Installation Type:
In-Ground Mount, Surface Mount

Finish Type:
Powder Coat



SE-5110 6FT STEEL BENCH W/O ARMS

Premier steel contour 6' bench. The frame is 2-3/8" steel tubing with 1-3/16" steel preformed slats. Powder coated in a variety of colors. Mounting options include direct bury or surface mount.

Installation Type:
In-Ground Mount, Surface Mount

Finish Type:
Powder Coat



SE-5120 6FT STEEL BENCH W/ ARMS

Premier steel bench flat 6' with preformed 1-1/2" steel seat slats welded to a 1-7/8" frame and 2"x 2" steel uprights. Powder coated in a variety of colors. Mounting options include direct bury or surface mount.

Installation Type:
In-Ground Mount, Surface Mount

Finish Type:
Powder Coat



SE-5115 6FT FLAT STEEL BENCH



**VISIT
WWW.PACIFICOOUTDOOR.COM
FOR MORE!**

SITE FURNISHINGS



SE-5125 6FT FLAT STEEL BENCH

Sleek, modern 6' all-steel slat bench. Frame is 2-3/8" welded steel tubing. Powder coated in a variety of colors. Mounting options include direct bury or surface mount.

Installation Type:
In-Ground Mount, Surface Mount

Finish Type:
Powder Coat

TRASH RECEPTACLES



SE-5630 STEEL TRASH RECEPTACLE

Architecturally designed powder coated steel trash receptacle. Dome lid sold separately.

Installation Type:
In-Ground Mount, Surface Mount

Finish Type:
Powder Coat



SE-5650 POLY TRASH RECEPTACLE

Attractive round trash receptacle. Round steel frame covered with 2x4 vertical slats. Available in recycled plastic. In-ground or surface mount installation. Dome lid sold separately.

Installation Type:
In-Ground Mount, Surface Mount

Finish Type:
Powder Coat

AVAILABLE STEEL COLORS:

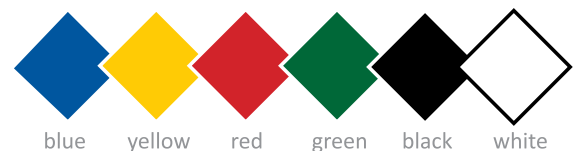



RECYCLED POLY TABLES



SE-5340 SUPER DUTY ADA TABLE

Available in four sided or a three-sided ADA (As Shown)

Installation Type: In-Ground Mount, Surface Mount
Finish Type: Powder Coat
ADA Accessible

Popular heavy duty four sided steel table with HDPE poly table tops and seats. The ADA version includes three seats to accommodate wheelchair access. Finish is powder coated. Surface or in-ground mount.



SE-5335 FOUR-SIDED TABLE

Available as a three-sided ADA Poly Table.

Installation Type: In-Ground Mount
Finish Type: Powder Coat



SE-5350 TWO SIDED 6FT. POLY TABLE

Installation Type: In-Ground Mount, Surface Mount
Finish Type: Powder Coat
ADA Accessible



SE-5330 J- FRAME TABLE

Installation Type: Free Standing
Finish Type: Powder Coat

RECYCLED POLY BENCHES



Single pedestal contour bench available in a 4' or 6' length. Main support is powder coated 4"x 4" steel tubing with 3/8" x 4" steel contour seat back. Seat options include 2"x 4" recycled plastic. Mounting options include direct bury or surface mount.

Installation Type:
In-Ground Mount, Surface Mount

Finish Type:
Powder Coat, HDPE Poly

SE-5130

6FT BENCH



Traditional 6' contour-back park bench with powder coated 2"x 2" vertical frames and 3/8"x 4" steel seat backs. Seat options include 2"x 4" recycled plastic. Mounting options include direct bury or surface mount.

Installation Type:
In-Ground Mount, Surface Mount

Finish Type:
Powder Coat, HDPE Poly

SE-5165

6FT POLY BENCH



Single pedestal contour bench available in a 4' or 6' length. Main support is powder coated 4"x 4" steel tubing with 3/8"x 4" steel contour seat back. Seat options include 2"x 4" recycled plastic. Mounting options include direct bury or surface mount.

Installation Type:
In-Ground Mount, Surface Mount

Finish Type:
Powder Coat, HDPE Poly

SE-5155 4FT OR 6FT POLY BENCH

VISIT
WWW.PACIFICOUTDOOR.COM
FOR MORE!

SITE FURNISHINGS

This 6' flat bench is a contemporary design, made from recycled plastic (poly.) The frame is fabricated of 2"x 2" carbon steel. Extremely heavy duty. This bench is designed to blend in to any outdoor environment. Powder coated in standard or custom colors. Mounting options include In-Ground or Surface Mount.

Installation Type:

In-Ground Mount, Surface Mount

Finish Type:

Powder Coat, HDPE Poly



SE-5135

6FT FLAT BENCH

Modern style 6' flat bench. Frames is heavy duty 2-3/8" powder coated steel tubing. Seat options include 2"x 4" recycled plastic. Mounting options include direct bury or surface mount.

Installation Type:

In-Ground Mount

Finish Type:

Powder Coat, HDPE Poly



SE-5140

6FT FLAT BENCH

Traditional flat bench available in 6' length. The support is made of 2"x 2" powder coated steel. Seat recycled plastic. Mounting options include direct bury or surface mount.

Installation Type:

In-Ground Mount, Surface Mount

Finish Type:

Powder Coat, HDPE Poly



SE-5145

6FT FLAT BENCH

AVAILABLE STEEL COLORS:

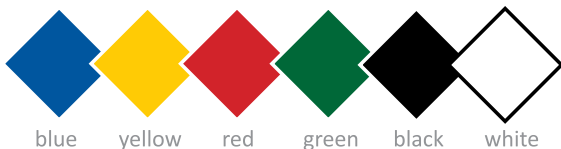

blue yellow red green black white

BICYCLE RACKS



SE-5570

Functional custom designed bike racks for cities, schools or any public area. Powder coated steel. Can be surfaced mounted or direct bury in the ground.

Installation Type:

In-Ground Mount, Surface Mount

Finish Type:

Powder Coat



SE-5575

Functional custom designed bike racks for cities, schools or any public area. Powder coated steel. Can be surfaced mounted or direct bury in the ground.

Installation Type:

In-Ground Mount, Surface Mount

Finish Type: Powder Coat



SE-5585

Continuous loop bike rack. Fabricated out of 1-7/8" heavy duty steel tubing. Available in standard 3-13 bike capacity, or can be made to custom length. Finish is powder coated in a wide range of colors. In-ground or surface mount installation.

Installation Type:

In-Ground Mount, Surface Mount

Finish Type: Powder Coat

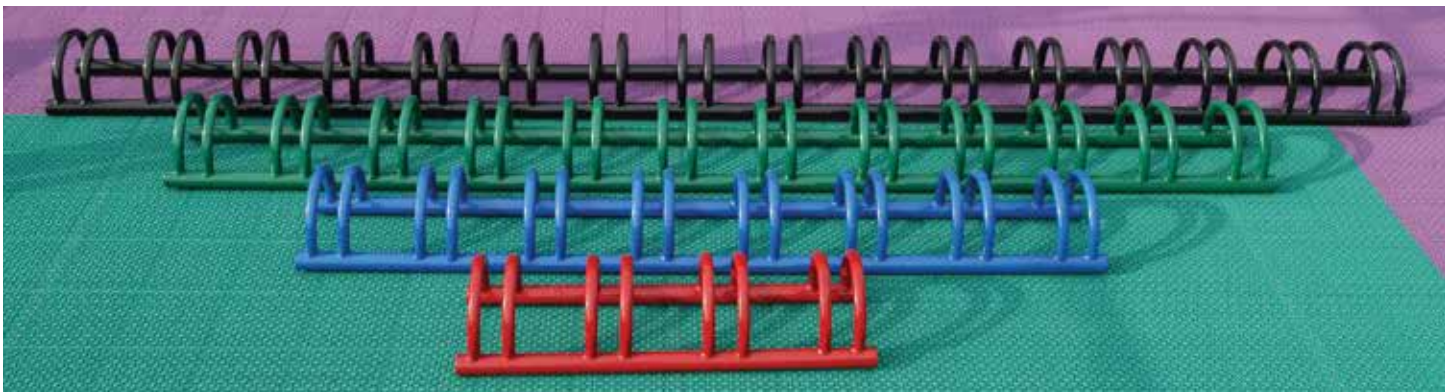

SE-5595

Functional custom designed bike racks for cities, schools or any public area. Powder coated steel. Can be surfaced mounted or direct bury in the ground.

Installation Type:

In-Ground Mount, Surface Mount

Finish Type: Powder Coat



STAYFIT BODYWEIGHT+ OUTDOOR FITNESS EQUIPMENT

StayFIT Systems outdoor/indoor bodyweight fitness equipment offers a wide selection of standard fitness designs. They can be installed outdoors or indoors in almost any setting. StayFIT equipment is perfect for any application; schools and universities, fitness centers and athletic clubs, apartments, parks, corporate centers, residential settings and much more. If a standard StayFIT design doesn't fit your needs we can quickly design a custom set that will.

WHY BODYWEIGHT FITNESS EQUIPMENT?

StayFIT is the most modular line of fitness equipment on the market today. StayFIT features over 40 different fitness activities that can be incorporated into an unlimited number of standard or custom designs. Every order is custom built by our factory craftsman using the highest quality materials. Every piece of equipment is built and inspected for quality assurance in our plant in Maple Valley Washington.

StayFIT offers the best warranty in the fitness industry! Check out the competition and see if they even come close to our 25-year warranty. StayFIT is a division of Pacific Outdoor Products; manufacturing the finest outdoor playground equipment, fitness equipment, and site furnishings since 1980.



FE-1110

10 REASONS TO BUY STAYFIT BODYWEIGHT FITNESS EQUIPMENT

- No moving parts to wear out.
- Low maintenance
- Cost effective
- The best warranty in the fitness industry
- Easy to install
- Easy to use
- Unlimited design capabilities
- Can be used by anyone, regardless of fitness level
- Can be used by all ages (recommend 13 years and up)
- Made in the USA

STAYFIT COLORS:

Each fitness system is powder coated in two of the standard colors below.

AVAILABLE COLORS:



CUSTOM COLORS AVAILABLE

Need to make your system match a logo or team colors? There are dozens of custom colors available.

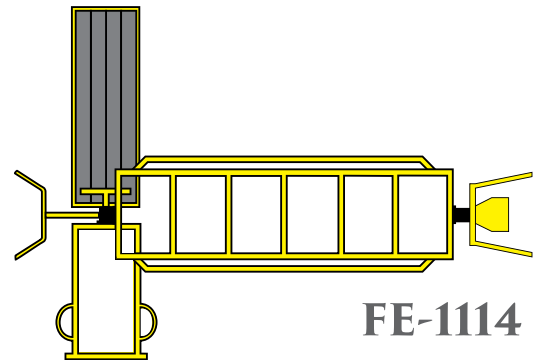

FE-1114

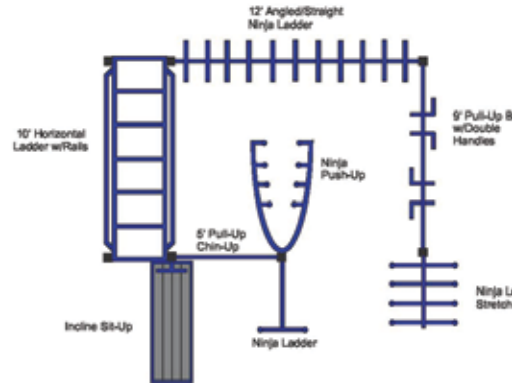

FE-1106

AREA NEEDED FOR SAFE USE:
26' x 30'

ACTIVITIES:
8

INSTALLATION:
In-Ground,
Surface Mount

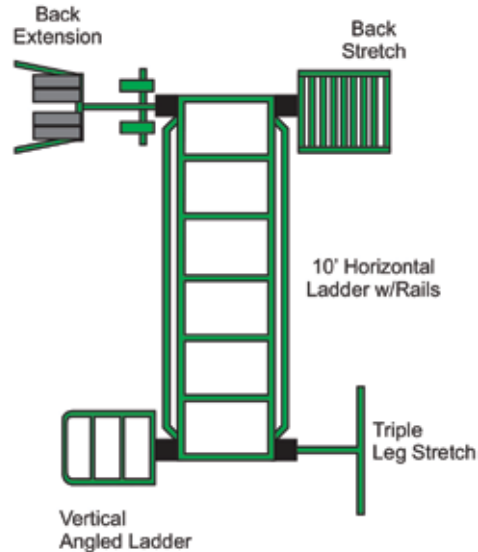

FE-1108

AREA NEEDED FOR SAFE USE:
18' x 20'

ACTIVITIES:
6

INSTALLATION:
In-Ground,
Surface Mount

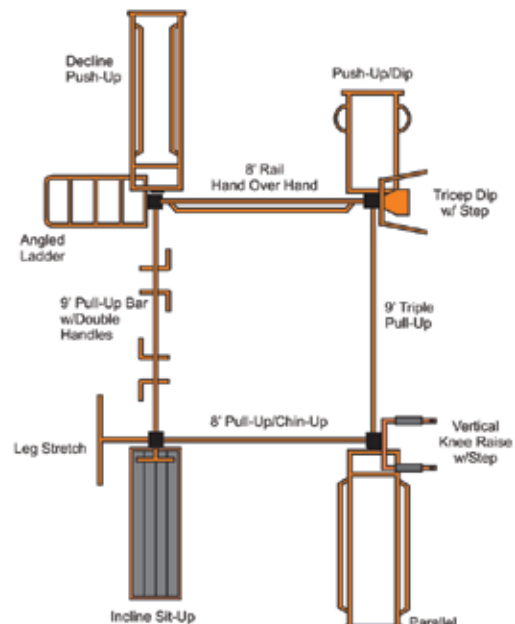

FE-1110

AREA NEEDED FOR SAFE USE:
24' x 32'

ACTIVITIES:
15

INSTALLATION:
In-Ground,
Surface Mount

VISIT
WWW.STAYFITSYSTEMS.COM
 FOR MORE!

STANDARD SYSTEMS



STAYFIT SYSTEMS

FE-1113

AREA NEEDED FOR SAFE USE:
 24' x 26'

ACTIVITIES:
 9

INSTALLATION:
 In-Ground,
 Surface Mount

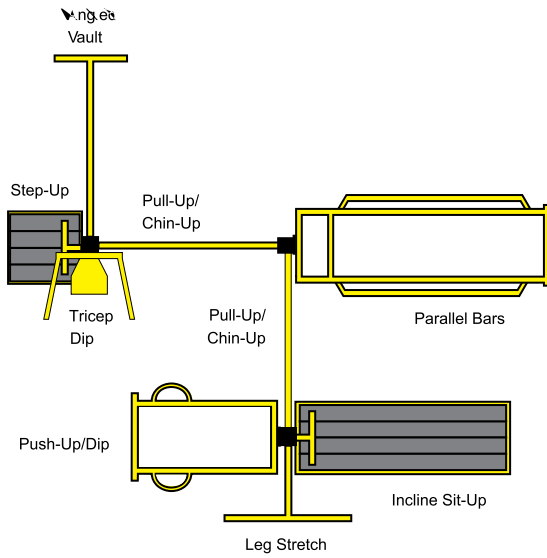

FE-1116

AREA NEEDED FOR SAFE USE:
 22' x 28'

ACTIVITIES:
 9

INSTALLATION:
 In-Ground,
 Surface Mount

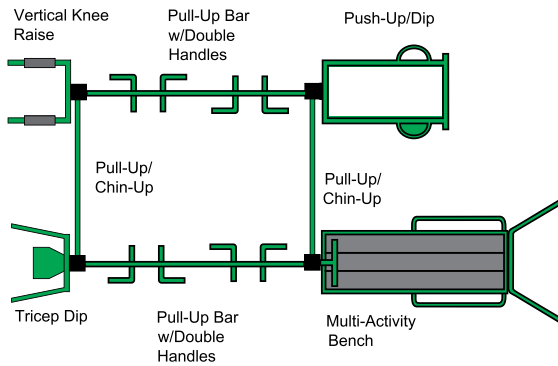

FE-1119

AREA NEEDED FOR SAFE USE:
 30' x 38'

ACTIVITIES:
 8

INSTALLATION:
 In-Ground,
 Surface Mount

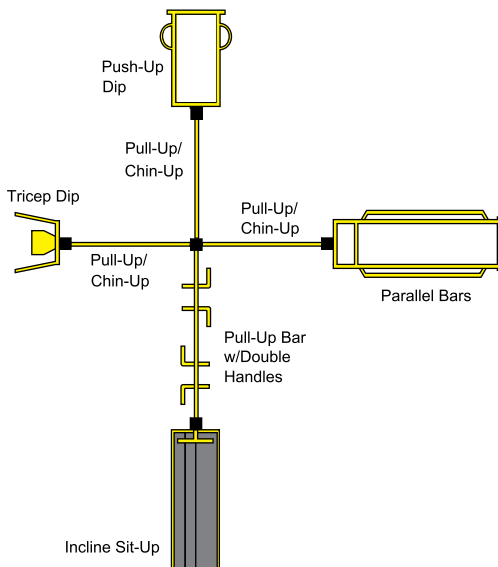

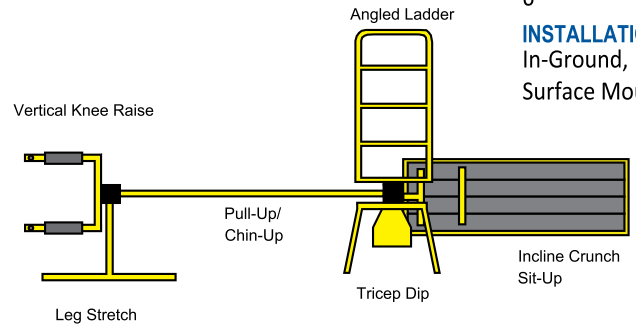

FE-1121

**AREA NEEDED
FOR SAFE USE:**
16' x 22'

ACTIVITIES:
6

INSTALLATION:
In-Ground,
Surface Mount

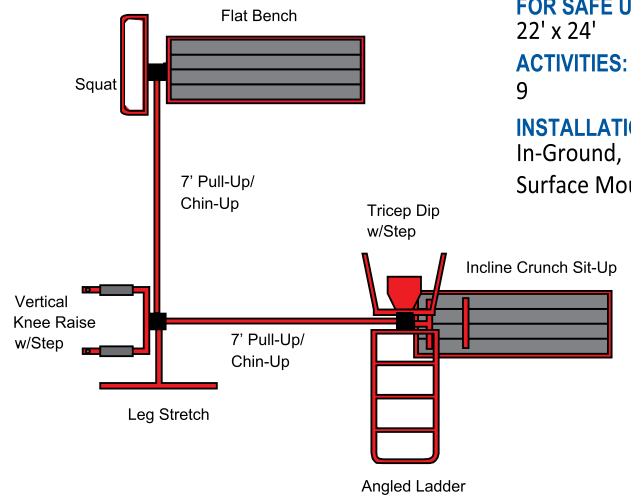

FE-1124

**AREA NEEDED
FOR SAFE USE:**
22' x 24'

ACTIVITIES:
9

INSTALLATION:
In-Ground,
Surface Mount

FE-1127

AREA NEEDED
FOR SAFE USE:
22' x 30'

ACTIVITIES:
6

INSTALLATION:
In-Ground,
Surface Mount

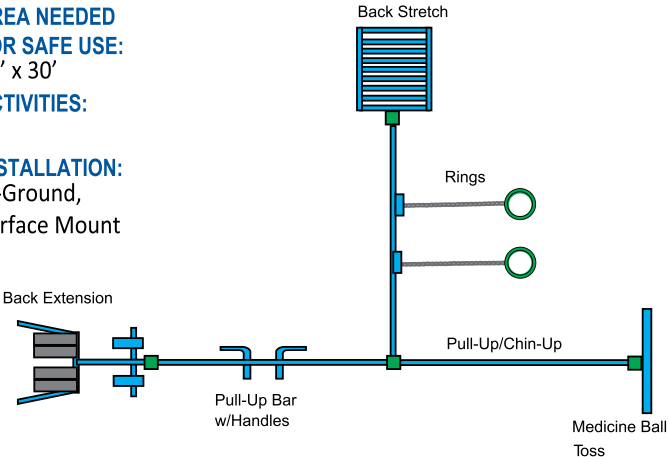

FE-1135

AREA NEEDED
FOR SAFE USE:
24' x 34'

ACTIVITIES:
11

INSTALLATION:
In-Ground,
Surface Mount

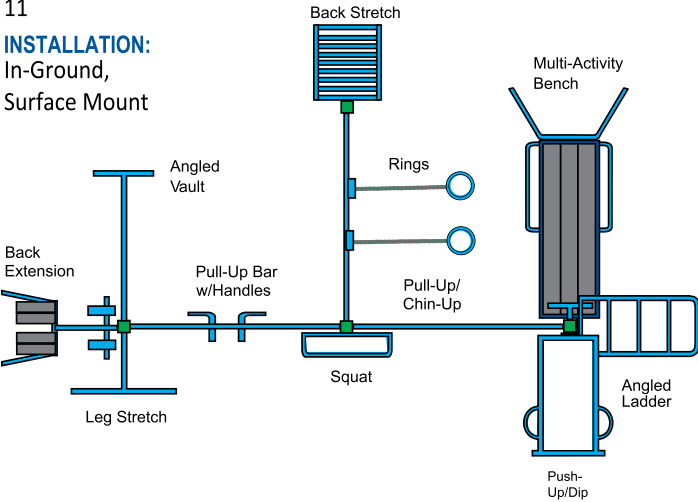

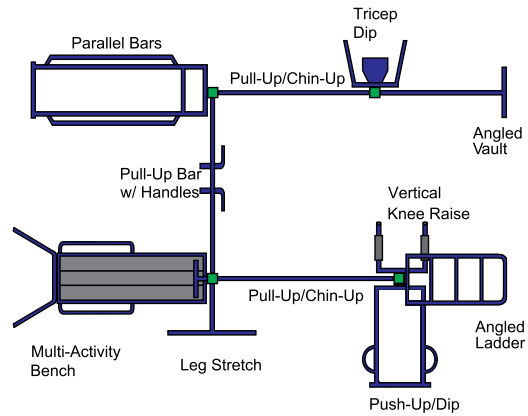

FE-1139

AREA NEEDED FOR SAFE USE:
26' x 30'

ACTIVITIES:
11

INSTALLATION:
In-Ground,
Surface Mount

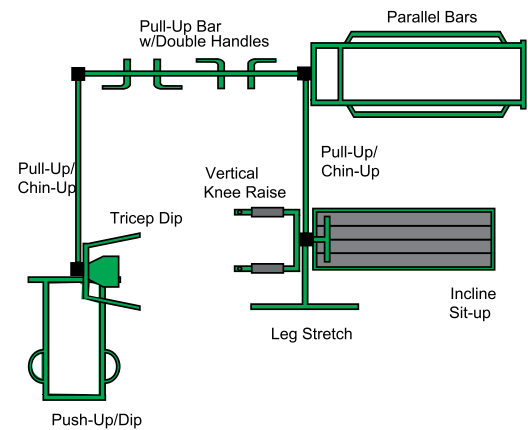

FE-1158

AREA NEEDED FOR SAFE USE:
26' x 26'

ACTIVITIES:
5

INSTALLATION:
In-Ground,
Surface Mount

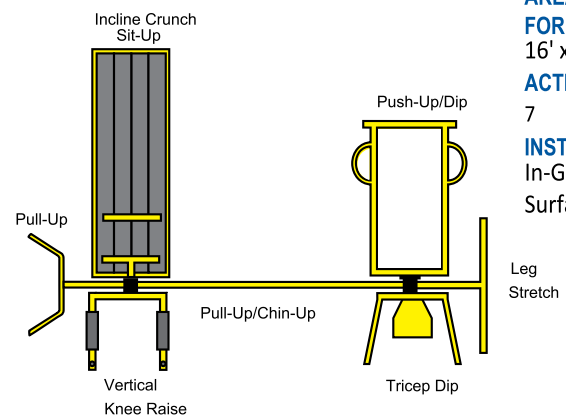

FE-1168

AREA NEEDED FOR SAFE USE:
16' x 24'

ACTIVITIES:
7

INSTALLATION:
In-Ground,
Surface Mount

FE-1169

AREA NEEDED FOR SAFE USE:
18' x 32'

ACTIVITIES:

6

INSTALLATION:
In-Ground,
Surface Mount

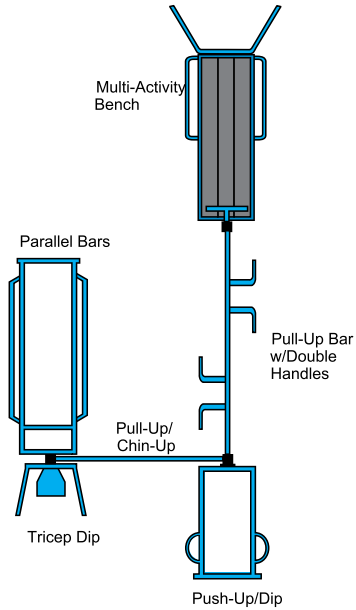

FE-1189

AREA NEEDED FOR SAFE USE:
18' x 18'

ACTIVITIES:
Multiple

INSTALLATION:
In-Ground,
Surface Mount



**Attachments not included

FE-1200

AREA NEEDED FOR SAFE USE:
30' x 34'

ACTIVITIES:
11

INSTALLATION:
In-Ground,
Surface Mount

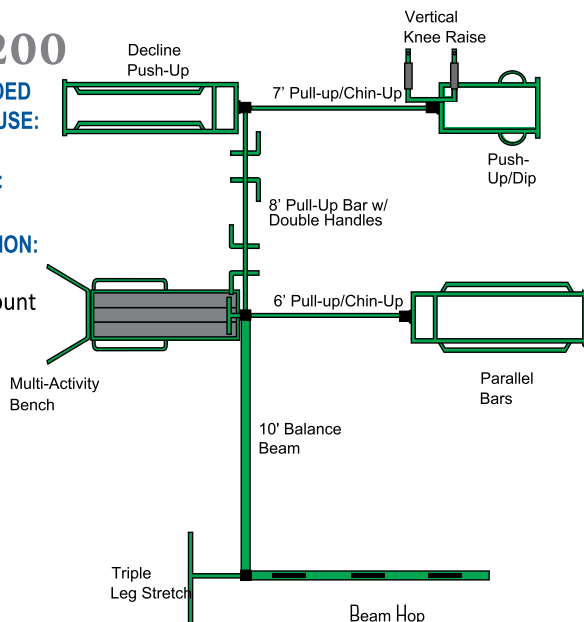

FE-1109

AREA NEEDED FOR SAFE USE: 3
16' x 16'

ACTIVITIES:

INSTALLATION: In-Ground, Surface Mount

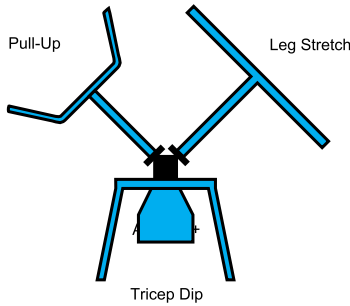

FE-1117

AREA NEEDED FOR SAFE USE: 8
26' x 34'

ACTIVITIES:

INSTALLATION: In-Ground, Surface Mount

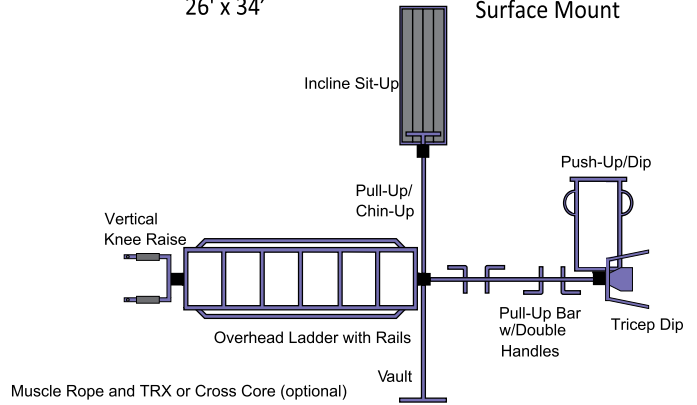

FE-1114

AREA NEEDED FOR SAFE USE: 5
22' x 26'

ACTIVITIES:

INSTALLATION: In-Ground, Surface Mount

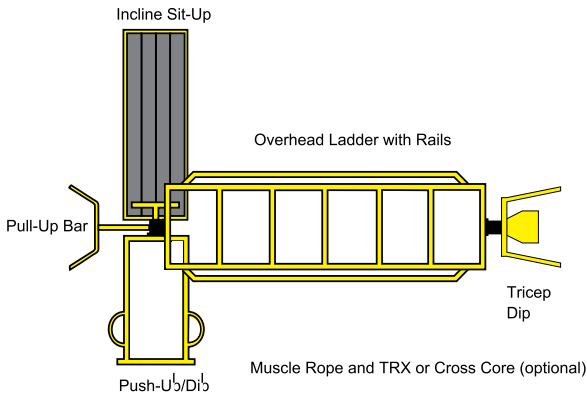

FE-1120

AREA NEEDED FOR SAFE USE: 3
12' x 28'

ACTIVITIES:

INSTALLATION: In-Ground, Surface Mount

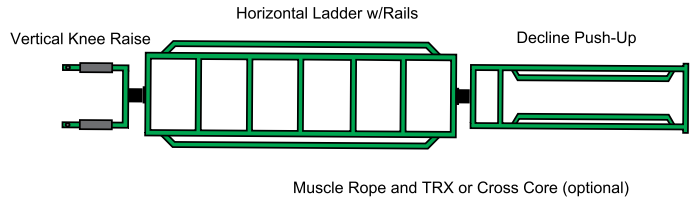

FE-1115

AREA NEEDED FOR SAFE USE: 10
18' x 34'

ACTIVITIES:

INSTALLATION: In-Ground, Surface Mount

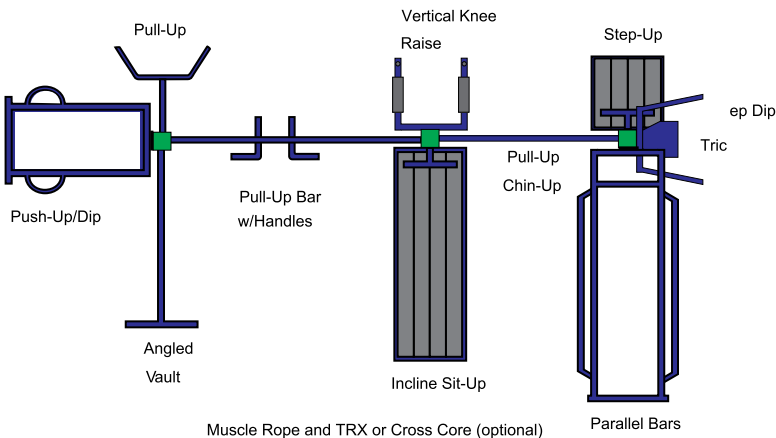

FE-1122

AREA NEEDED FOR SAFE USE: 5
24' x 26'

ACTIVITIES:

INSTALLATION: In-Ground, Surface Mount

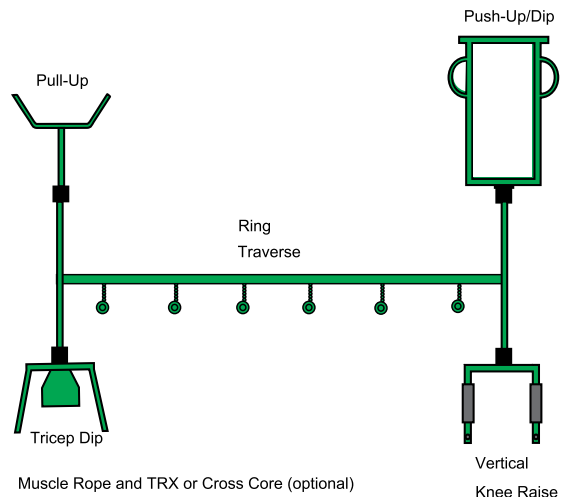

FE-1125

AREA NEEDED **ACTIVITIES:** **INSTALLATION:**
FOR SAFE USE: 7 In-Ground,
23' x 28' Surface Mount

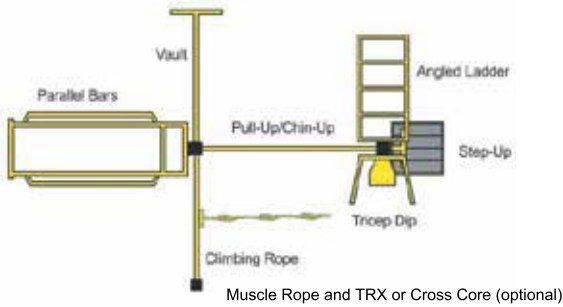

FE-1143

AREA NEEDED **ACTIVITIES:** **INSTALLATION:**
FOR SAFE USE: 9 In-Ground,
26' x 30' Surface Mount

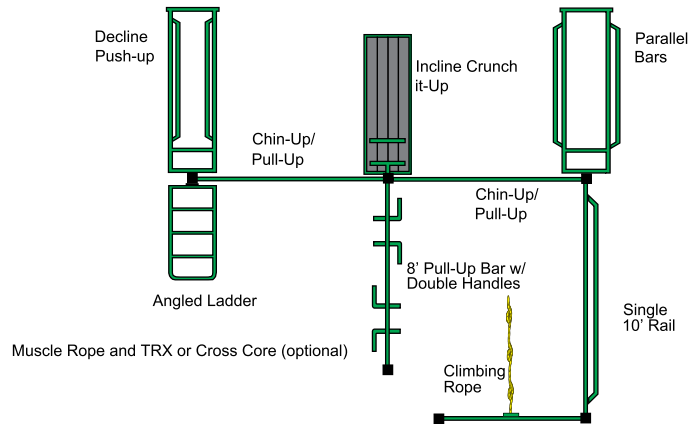

FE-1129

AREA NEEDED **ACTIVITIES:** **INSTALLATION:**
FOR SAFE USE: 10 In-Ground,
30' x 32' Surface Mount

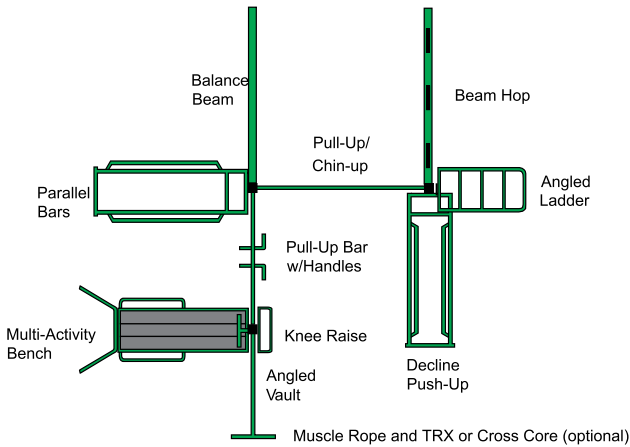

FE-1145

AREA NEEDED **ACTIVITIES:** **INSTALLATION:**
FOR SAFE USE: 26 In-Ground,
40' x 50' Surface Mount

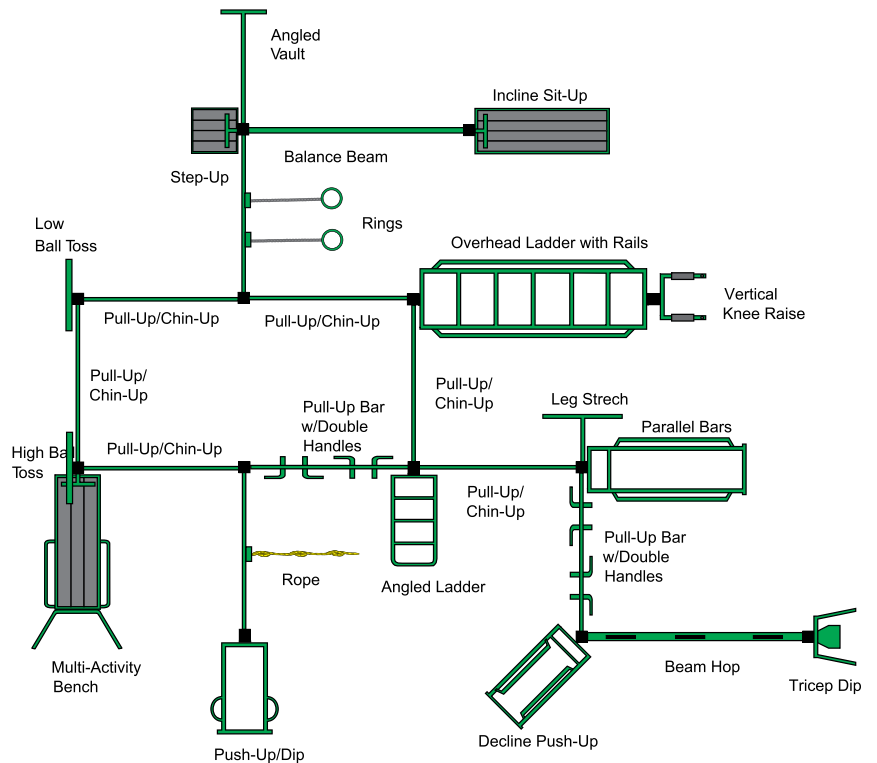

FE-1133

AREA NEEDED **ACTIVITIES:** **INSTALLATION:**
FOR SAFE USE: 7 In-Ground,
18' x 34' Surface Mount

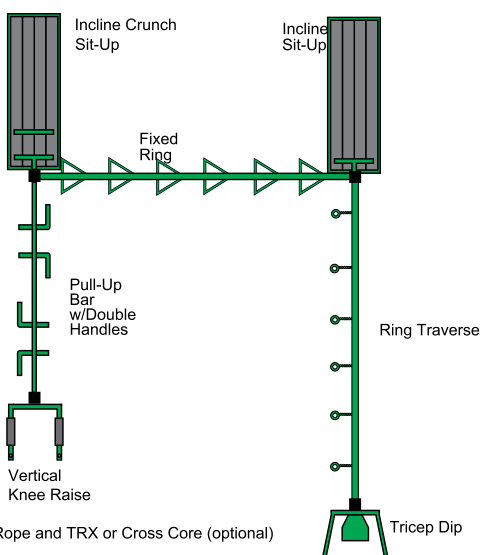

AVAILABLE STEEL COLORS:

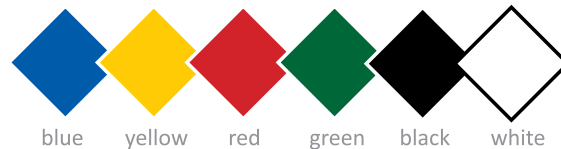

FE-1146

AREA NEEDED FOR SAFE USE: 4
16' x 24'

ACTIVITIES: Pull-Up

INSTALLATION: In-Ground, Surface Mount

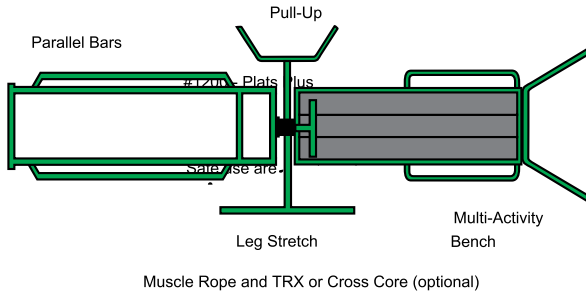

FE-1148

AREA NEEDED FOR SAFE USE: 3
9' x 30'

ACTIVITIES: Pull-Up Bar w/Double Handles

INSTALLATION: In-Ground, Surface Mount

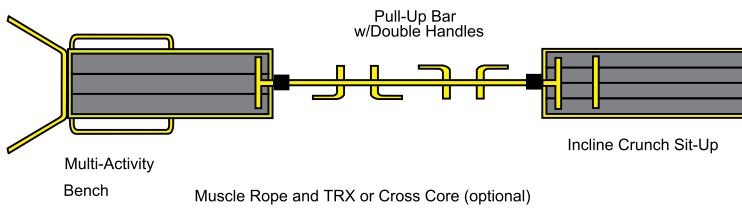

FE-1151

AREA NEEDED FOR SAFE USE: 5
36' x 15'

ACTIVITIES: Wide-Grip Pull-up Handles

INSTALLATION: In-Ground, Surface Mount

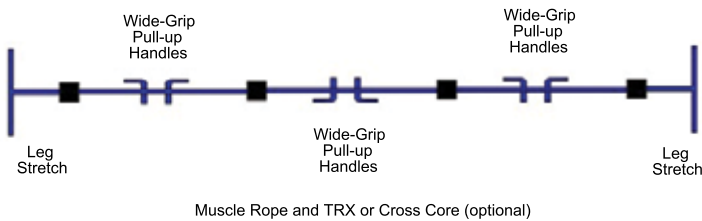

FE-1170

AREA NEEDED FOR SAFE USE: 6
24' x 28'

ACTIVITIES: Leg Stretch, Ring Traverse (84" high), Ring Traverse (78" high), Squat, Pull-Up (low), Pull-Up (high)

INSTALLATION: In-Ground, Surface Mount

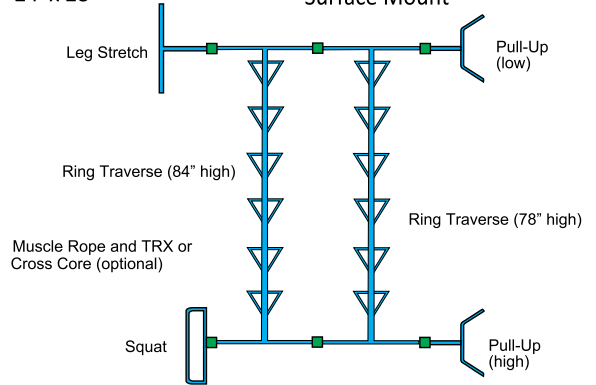

FE-1184

AREA NEEDED FOR SAFE USE: 5
24' x 26'

ACTIVITIES: Angled Vault, Ring Traverse, Back Stretch, Beam Hop, Back Extension

INSTALLATION: In-Ground, Surface Mount

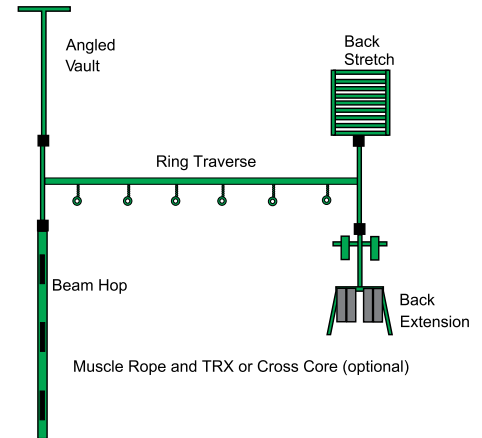

FE-1188

AREA NEEDED FOR SAFE USE: 11
36' x 38'

ACTIVITIES: Rope Climb, Squat, 90° Balance Beam, 10' Angled Loop Ladder, Tricep Dip, Leg Stretch, 12" Fixed Ring Traverse, Decline Push-Up, Beam Hop, Angled Ladder, Pull-Up/Chin-Up

INSTALLATION: In-Ground, Surface Mount

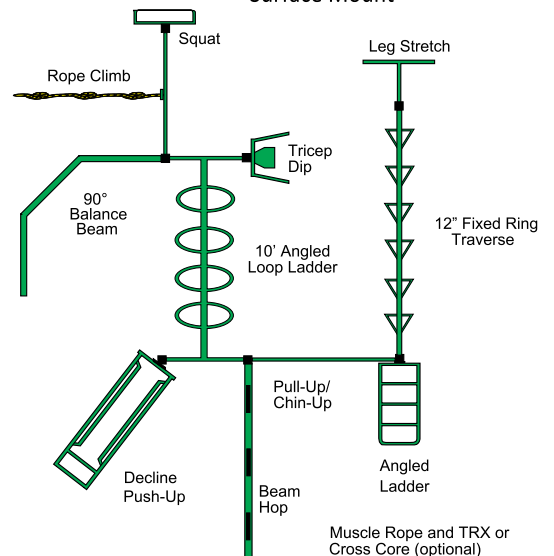

ExerTRAC fitness trail equipment is designed to be the most modular fitness trail equipment available. Your new ExerTRAC fitness equipment will be built using the highest quality materials. Every part is custom made for your order by our expert craftsman; just as it has been done since 1980. As a result, we can offer the best warranty in the fitness industry; a full 25 years!

ExerTRAC has over 40 different bodyweight exercise stations recommended for those aged 13 years and up. Because ExerTRAC has no moving parts it is almost maintenance free, simple to install, and can be designed to fit nearly any budget.



DESIGN YOUR OWN CUSTOM EXERTRAC SYSTEM

StayFIT outdoor fitness equipment is built to order so you have the option of having us design the perfect fitness set or stations to fit your space, budget and needs at no extra cost!

This is all we need to create your perfect outdoor fitness center.

- The fitness stations you would like.
- The size of the space for the equipment.
- Choice of any 2 of the 10 standard colors.
- Will it be installed in-ground or surface mount on a concrete slab.
- Project budget.

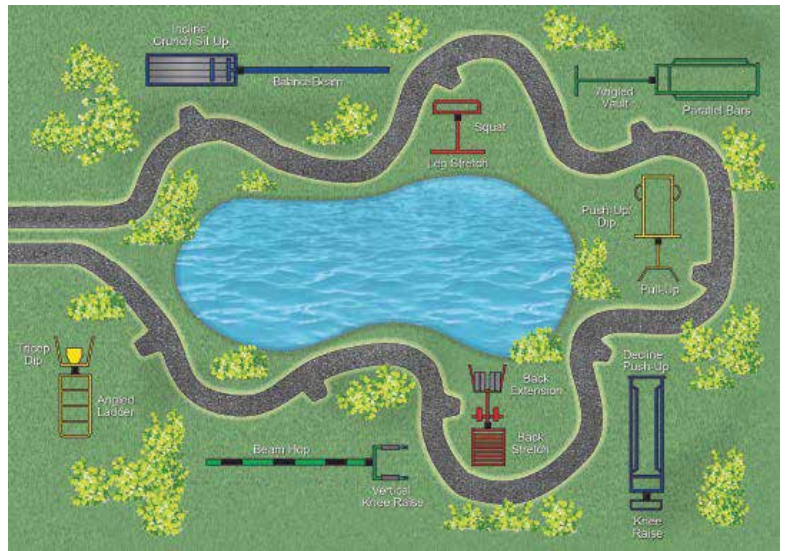



FE-1302 Ninja Climber



FE-1304 Ninja Push-up



FE-1306 Ninja Leg Stretch



FE-1310 Multi-purpose bench and push-up/triceps dip



FE-1313 Plyo Jump



FE-1314 Jump Up



FE-1315 Triple Pull Up



FE-1316 Angled Hand Over Hand



FE-1317 Balance Walk

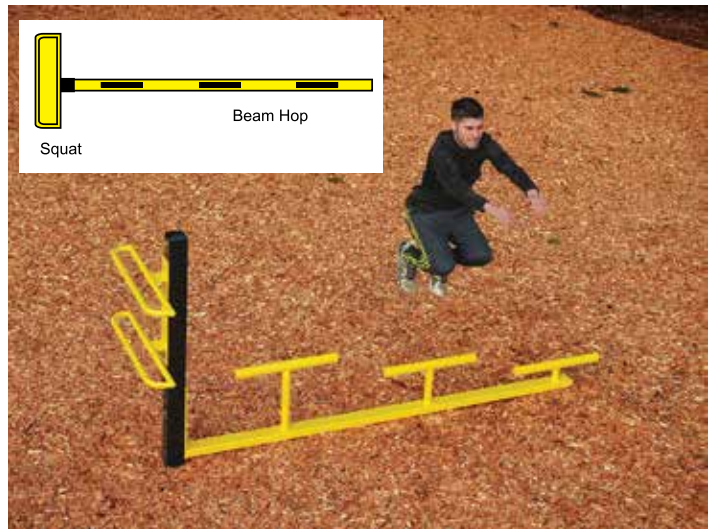

FE-1320 Squat and Beam hop

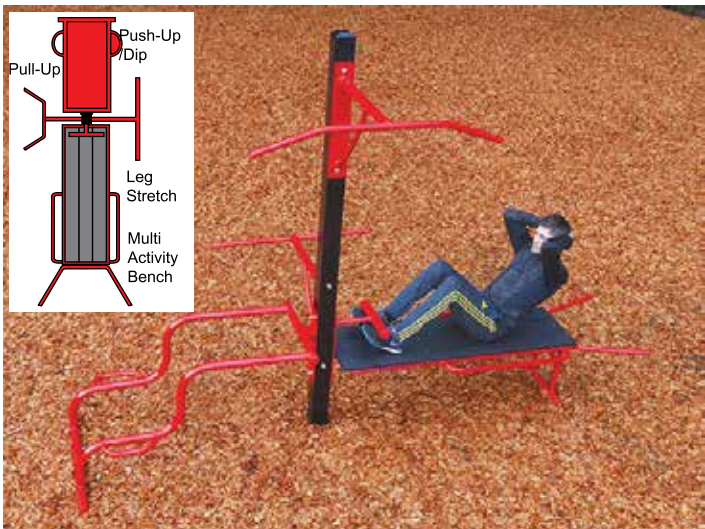

FE-1322 Pull-up, leg stretch, multi-purpose bench, Push-up dip

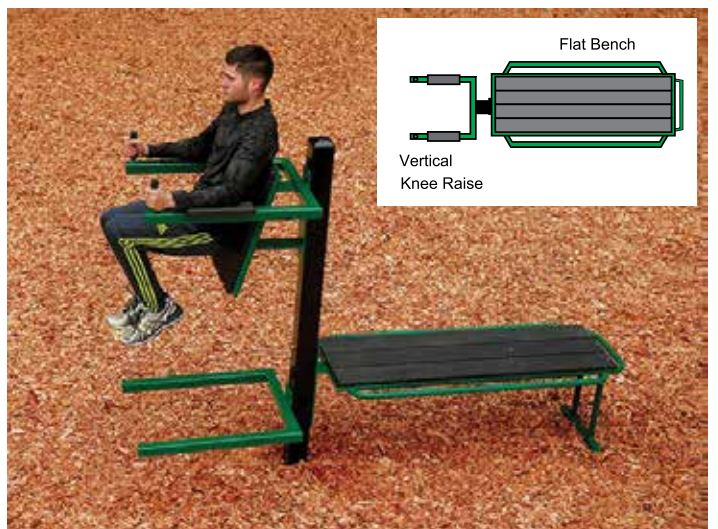

FE-1327 Flat bench and Vertical knee raise

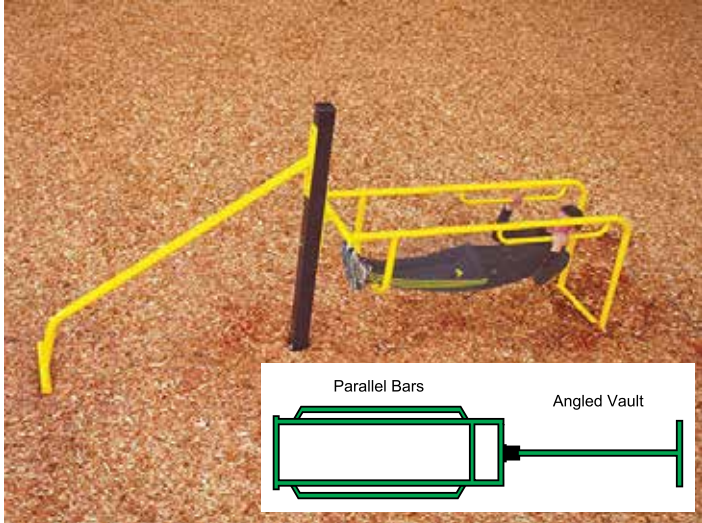

FE-1330 Vault and Parallel Bars



FE-1331 Rope Climb

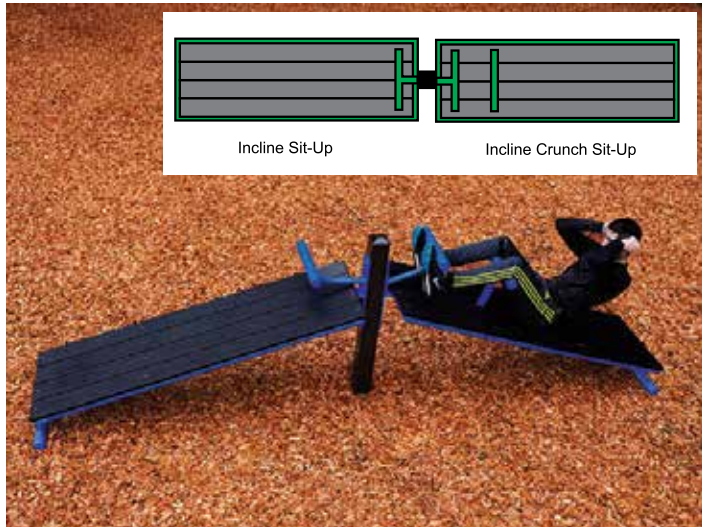

FE-1332 Incline sit-up bench and crunch sit up bench



FE-1334 Pistol Squat



FE-1339 Triceps dip and angle ladder
PACIFIC OUTDOOR PRODUCTS, INC.



FE-1340 Back Stretch and Back Extension

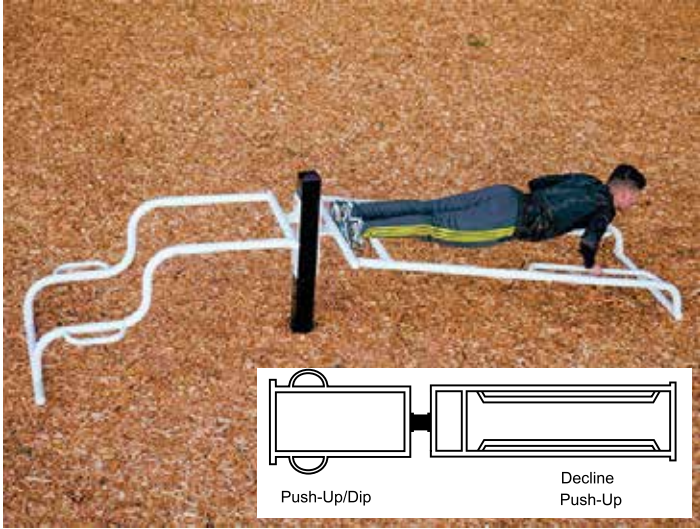

FE-1345 Decline push-up and push-up/triceps dip



FE-1346

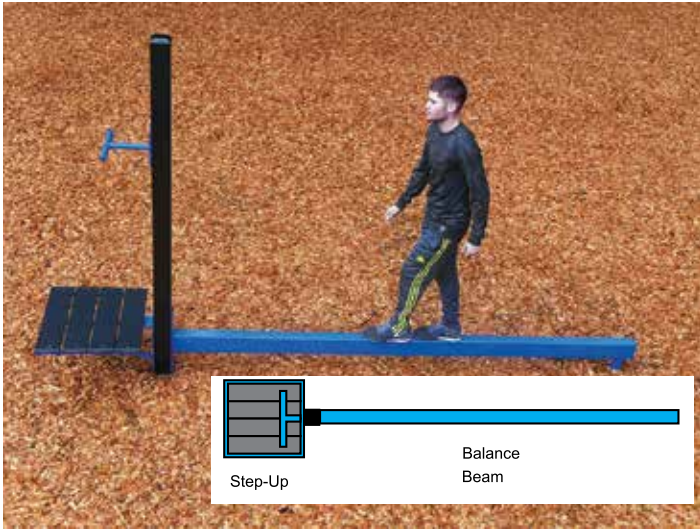

FE-1355 Balance Beam, step-up



FE-1357 Upper-lower ball toss



FE-1358 Leg raise – triple leg stretch

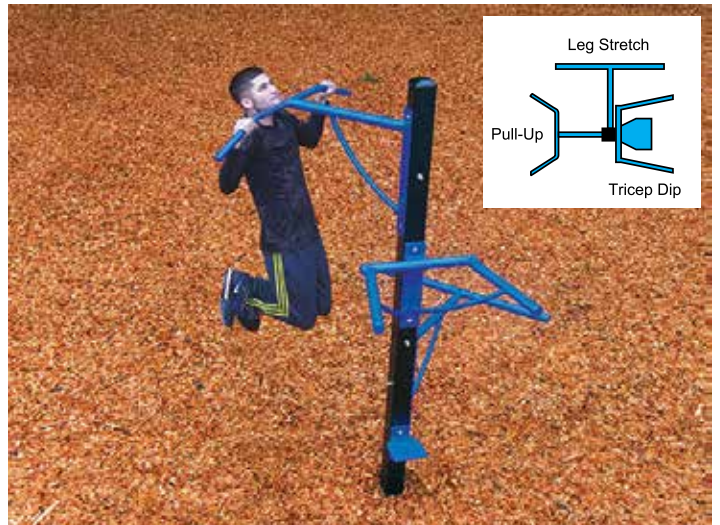

FE-1360 Pull-up – leg stretch – triceps dip



FE-1366 Vertical Angle Climber



FE-1368 Vertical Ladder

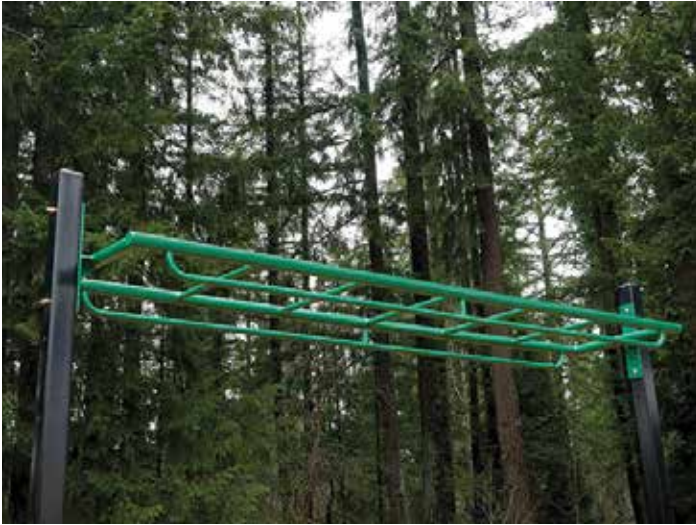

FE-1372 Overhead Ladder With Rails



FE-1376 Level Loop Ladder



FE-1378 Angled Loop Ladder



FE-1380 Angled Ninja Ladder



FE-1382 Straight Ninja Ladder



FE-1384 Fixed Loop Traverse



FE-1386 Swinging Rings



FE-1388 Rail Hand Over Hand



MULTI-USE POLE STATIONS

- Bands
- Suspension Trainer
- Battle Ropes

* Attachments Not Included

ExerCOURT fitness equipment is designed for tennis courts, multi-use courts and backyard game courts.

ExerCOURT can transform any commercial or residential court into an outdoor fitness center. If you just want to provide a simple “warm-up” station or a full-blown bodyweight training area we can design the equipment to suit your needs. This is the simplest way to have your own personal gym in your backyard. We offer over 30 different bodyweight exercise stations to choose from! Sit-ups, push-ups (normal, wide and decline), parallel bars, knee raises, triceps dips, muscle ropes, TRX attachments just to name a few. Everything is commercial quality and hand made in the USA by our in-house craftsman.

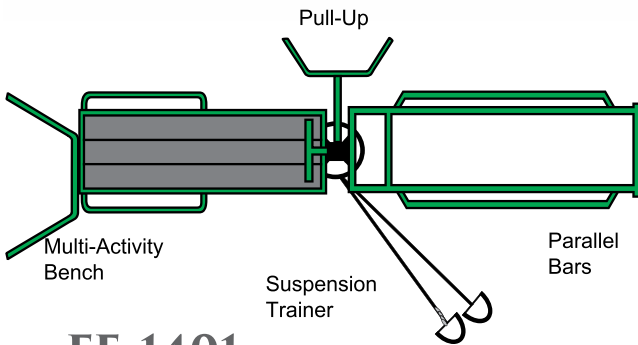
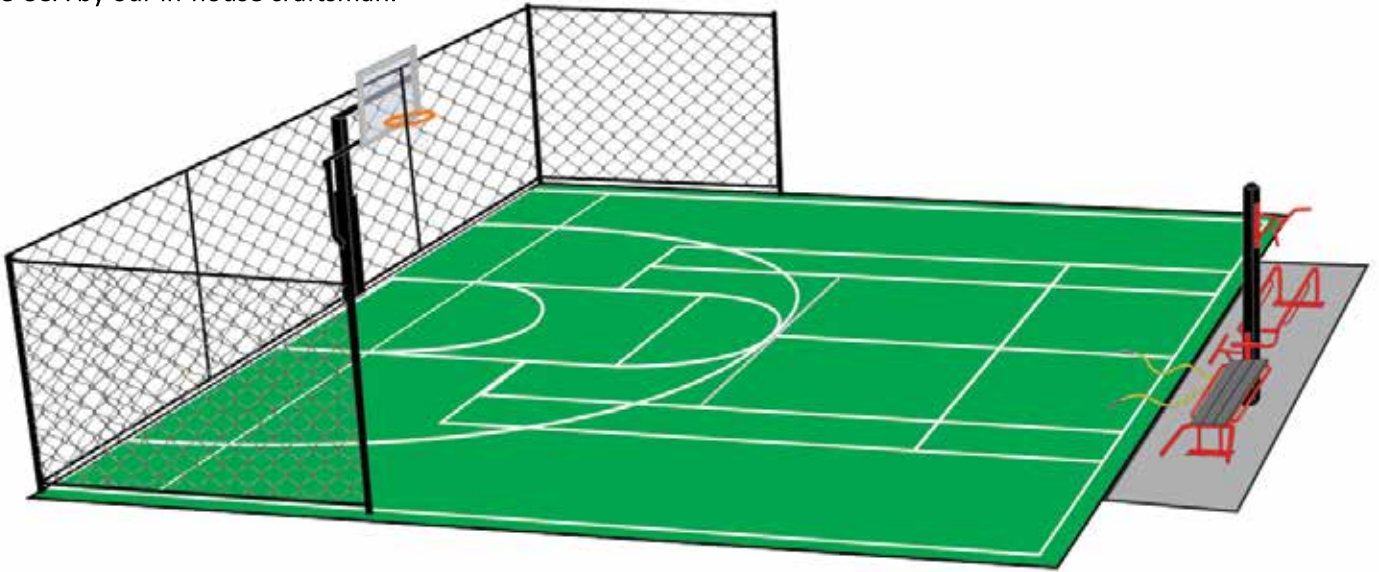

FE-1401

Safe-Use Area: 14' x 22'

Installation: Court Sleeve, In-Ground, Surface Mount

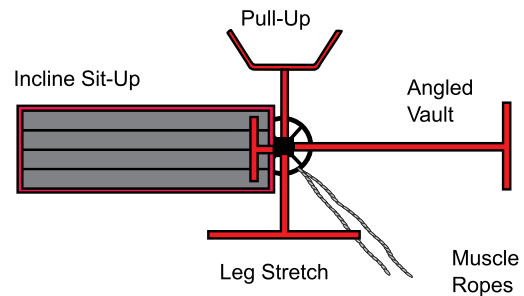

FE-1400

Safe-Use Area: 14' x 14'

Installation: Court Sleeve, In-Ground, Surface Mount

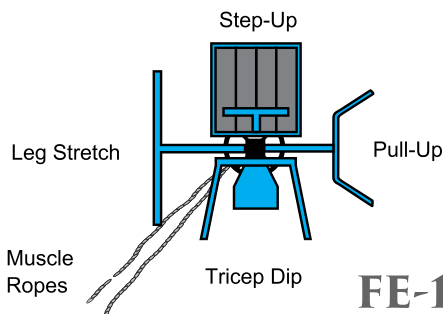

FE-1402

Safe-Use Area: 12' x 14'

Installation: Court Sleeve, In-Ground, Surface Mount

- Suspension trainer and muscle/battle ropes go into the court to be used effectively.
- TRX suspension training equipment is not included.
- Muscle ropes/battle ropes are included.

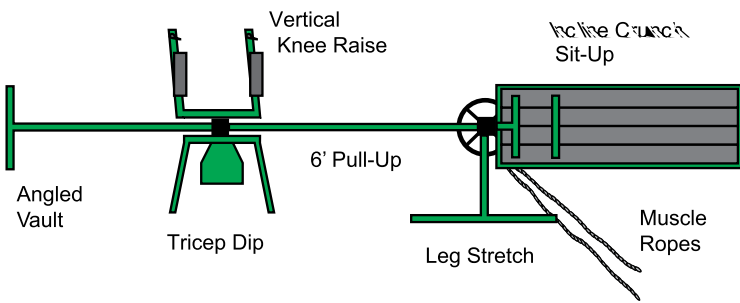
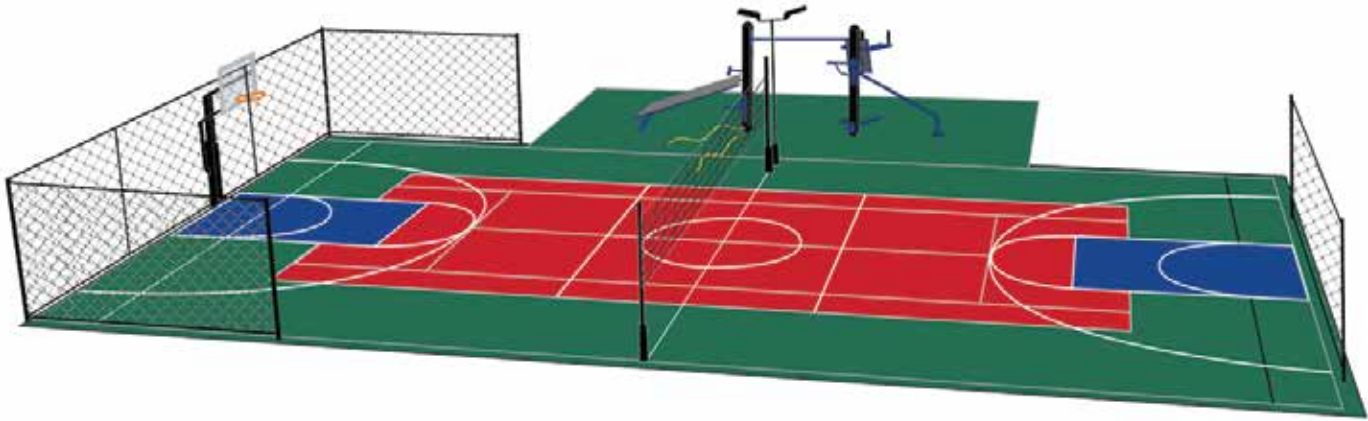

FE-1403

Safe-Use Area: 14' x 24'

Installation: Court Sleeve, In-Ground, Surface Mount

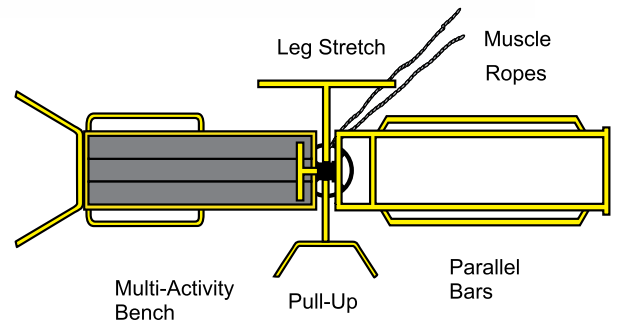

FE-1404

Safe-Use Area: 14' x 24'

Installation: Court Sleeve, In-Ground, Surface Mount

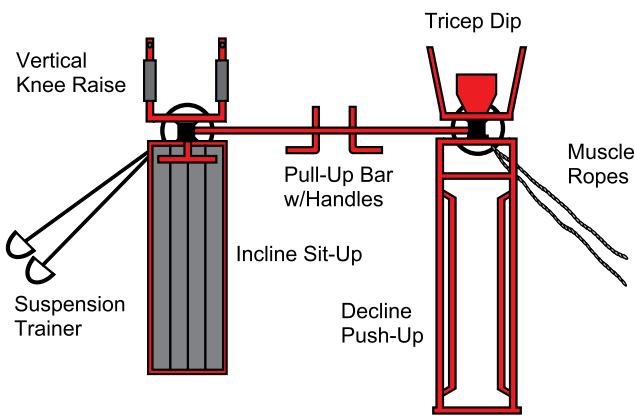

FE-1405

Safe-Use Area: 16' x 16'

Installation: Court Sleeve, In-Ground, Surface Mount

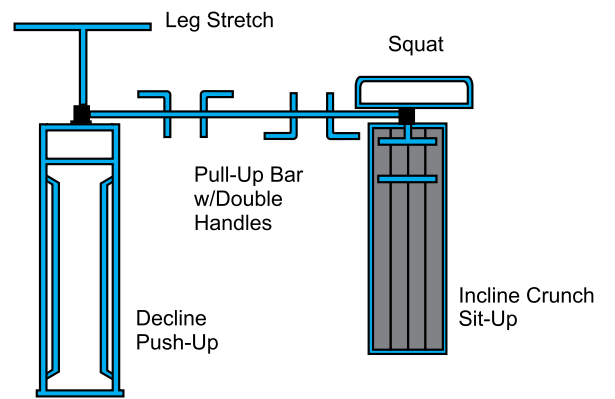

FE-1406

Safe-Use Area: 18' x 20'

Installation: Court Sleeve, In-Ground, Surface Mount

AVAILABLE STEEL COLORS:

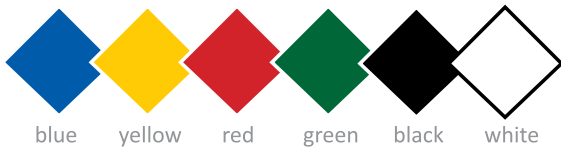

blue yellow red green black white

Aging is not an excuse to avoid exercise! The older people become the more important it is to have a regular exercise routine. A good exercise program helps maintain flexibility, strength, energy, endurance, improve overall health and reduce the risk of health related problems that increase with aging.



Past the age of 35, muscle loss of up to 5% occurs with each decade. Regular exercise can greatly improve both health and longevity! The Center for Disease control states that “regular physical activity is one of the most important things older adults can do for their health”. Physical activity can also help reduce the risk of falls, which are a significant health concern in older adults.

There are 4 types of exercise: Flexibility, Strength, Endurance, and Balance. StayFIT outdoor fitness equipment is designed to provide all four types of exercise.

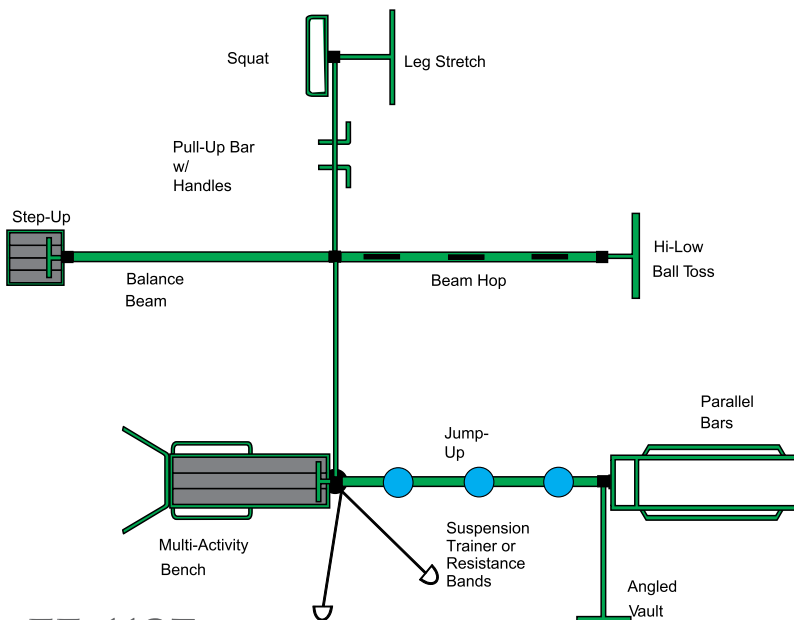

FE-1187

Safe-Use Area: 24' x 38'

Installation: In-Ground, Surface Mount

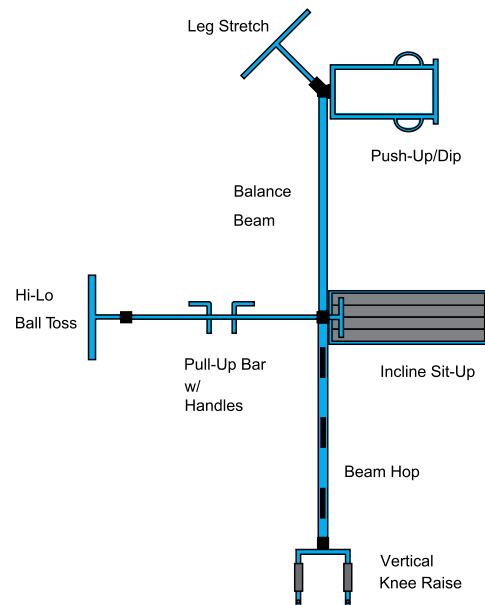

FE-1190

Safe-Use Area: 28' x 36'

Installation: In-Ground, Surface Mount

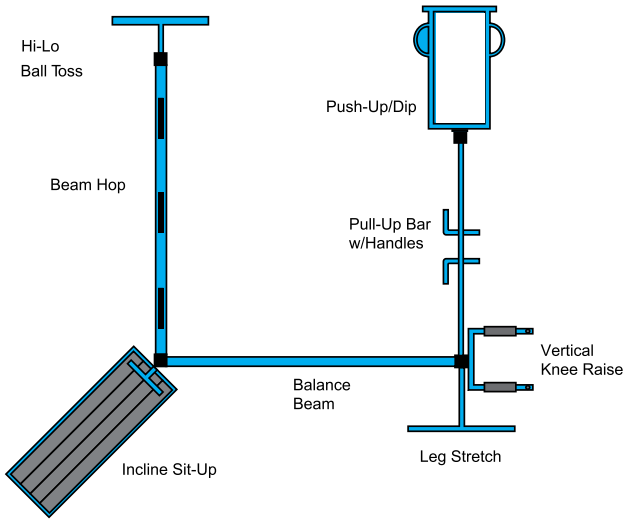

FE-1191

Safe-Use Area: 28' x 30'
Installation: In-Ground, Surface Mount

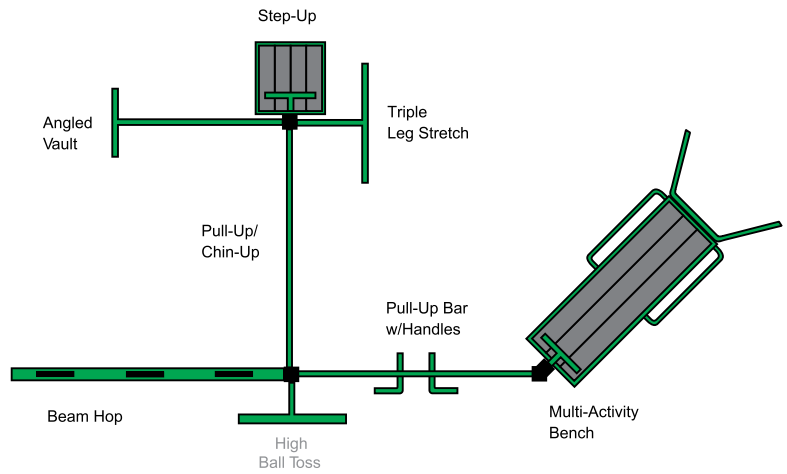

FE-1192

Safe-Use Area: 26' x 36'
Installation: In-Ground, Surface Mount

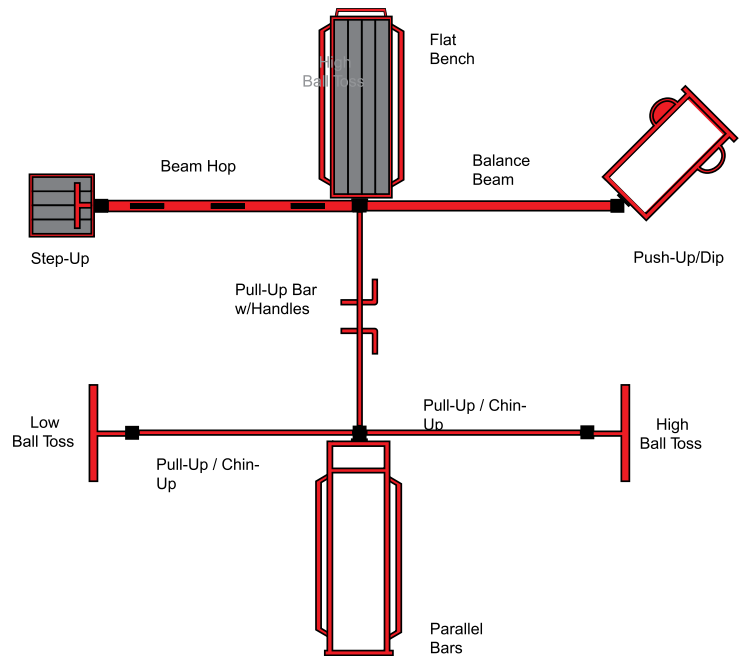

FE-1195

Safe-Use Area: 30' x 42'
Installation: In-Ground, Surface Mount

SUPER BODY-WEIGHT FITNESS EQUIPMENT MAX

Super Duty Fitness Stations for Prison and Correctional Facilities, Military, Police, Fire or Extreme use Applications.

SuperMAX Correctional Fitness Equipment is hand made in the USA and designed specifically for use in almost any environment! SuperMAX is the perfect fitness addition for prisons, correctional facilities, military installations, police departments, fire departments, or any application where only the toughest and heaviest duty equipment will work.

Manufactured with oversized steel components, thicker wall sizes, hand welded, Powder coated, and stainless steel hardware (tamper resistant hardware is available). SuperMAX has no moving parts for minimal maintenance and our 25-year warranty makes it the best product for your existing or new workout facility.



SuperMAX 2.5

Tamper Resistant Hardware

SuperMAX correctional facility and prison exercise equipment is the most “Inmate” resistant equipment on the market. No light gauge steel is used in SuperMAX equipment. The structure is hand-welded using the strongest materials; schedule 40 tube and 3/16’ to 3/8” thick flat and square carbon steel. It is simply the toughest prison equipment built, and with our 25 year coverage, has the best warranty in its field.



SuperMAX Outdoor/indoor fitness equipment is strictly bodyweight equipment and requires no moving parts, cables, weights, pulleys or other components which could sustain damage or need replacement. Everything is hand-welded, pre-drilled, and then bolted together using heavy-duty tamper resistant hardware, making a perfect fit for prison exercise equipment.



SuperMAX 4

- 4 Seperate exercise stations
- 7 Seperate exercises
- Small Footprint 5' x 8'
- Recommended use area 12' x 15'



SuperMAX 5

- 4 Seperate exercise stations
- 14 Seperate exercises
- Small Footprint 5' x 8'
- Recommended use area 12' x 15'



SuperMAX 6

- 6 Seperate exercise stations
- 10 Seperate exercises
- Small Footprint 5' x 8'
- Recommended use area 12' x 15'





SUPERMAX



SuperMAX 10

- 10 Seperate exercise stations
- 16 Seperate exercises
- Footprint 14' x 16.5'
- Recommended use area 22' x 27'

SuperMAX 8

- 8 Seperate exercise stations
- 12 Seperate exercises
- Footprint 13' x 14'
- Recommended use area 19' x 23'



SuperMAX 12

- 12 Seperate exercise stations
- 14 Seperate exercises
- Footprint 14' x 21'
- Recommended use area 22' x 27'

SuperMAX Individual Fitness Stations

SuperMAX bodyweight fitness equipment is hand made in the USA and designed specifically for use in almost any environment! SuperMAX is the perfect fitness addition for prisons, correctional facilities, military installations, police departments, fire departments, or any application where only the toughest and heaviest duty equipment will work.

Manufactured with oversized steel components, thicker wall sizes, hand welded, powder coated and all stainless steel hardware (tamper resistant hardware is available). SuperMAX has no moving parts for minimal maintenance and our 25-year warranty makes it the best product for your existing or new workout facility.

Individual Stations & Custom Design

SuperMAX individual stations can be purchased as a single unit, in groups, or they can be linked together to accommodate multiple users at one time. The photos below show the available SuperMAX stations you can mix or match to create the perfect outdoor fitness area. SuperMAX can also be designed in phases so you can easily add on to them as your space and budget allows.



1

Parallel bars & pull-up
4 Exercises



2

Knee raise, pull-up & squats
2 Exercises



3

Step-up, pull-up & push-up
3 Exercises



4

Four-person pull-up



5

Two-person pull-up



6

Two-person pull-up, vertical
knee raise & triceps dip



7

Triceps dip & incline sit-up



8

Pistol squat & pull-up



9

Vertical knee raise & triceps dip



10

Vertical knee raise & incline sit-up



11

Decline push-up & pull-up



12

Vertical knee raise, parallel bars & pull-up



13

Vault, pull-up & push-up



14

Decline push-up, triceps-dip & pull-up



15

Pull-up & squat



16

Back extension & pull-up



17

Incline sit-up & crunch sit-up



Wall-Mount Stations

In addition to our multi-functional fitness stations, we offer a complete line of individual fitness stations that can be installed as single free-standing units or wall mounted when space is an issue.

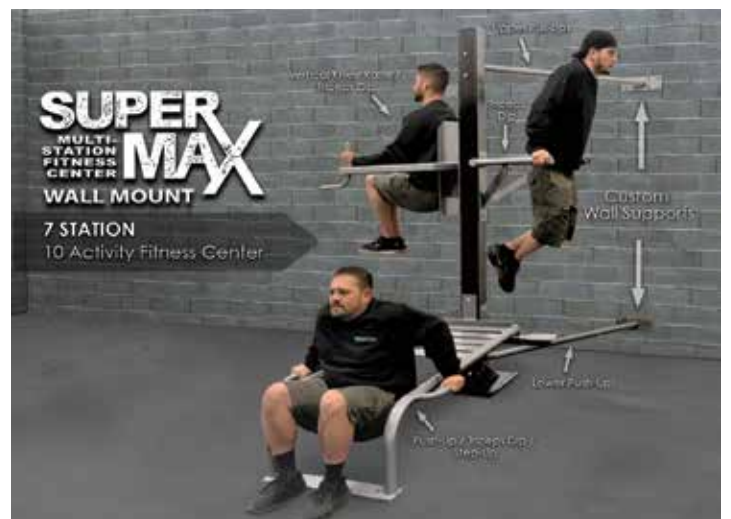

SuperMAX Wall Mount Station

SuperMAX wall mounted exercise stations bolt directly to a vertical wall and are compatible with wood, concrete, or block walls. Wall mounted fitness stations conserve floor space and allow more room for other activities and are the perfect solution when limited space is an issue. Stations are easy to install and maintain as they are simply bolted to the wall and can, in addition, be secured to the floor where needed. If you have a limited space for your fitness area SuperMAX wall mount fitness stations are a great choice for your fitness workout area.

Space Saving Fitness Stations

Choose from the fitness stations shown below to design your new workout area. Please keep in mind you must have a solid wall for attachment. All of the stations are manufactured out of heavy gauge steel, welded, and powder coated in any 1 of our 12 standard colors. You will not find better built, stronger, or longer lasting fitness equipment.

Pacific Outdoor Products does not provide any attaching or anchoring hardware for our wall mounted equipment. Anchoring or attaching hardware you will need will depend upon the type of wall the equipment will be mounted to. Common installations will be on a concrete, concrete block, or wood frame wall. The customer will determine the type of wall they will use and provide the hardware required to provide a safe and secure installation.

If you are unsure of the type of attaching hardware you need you should consult a contractor who is skilled in this type of work. You may also need anchoring hardware to attach the ground level stations to the floor.



1 Vertical Knee Raise



2 Triceps Dip



3 Squat



4 Push-Up / Dip / Step-Up



5 Lower Sit-Up Bar



6 Leg Stretch



7 Incline Sit-Up



8 Step-Up



9 Pull-Up



10 Back Stretch / Let Lift



11 Vault



12 Crunch Sit-Up



13 Multi-Use Parallel Bars

**SUPER
MAX****SUPERMAX**

Extreme Mini Bench - 7 Stations & Activities

The SuperMAX 7 Station Extreme Mini is a compact version of the SuperMAX 10 Station Extreme bench, just a tough with a smaller footprint. The mini weighs 260 pounds and can accommodate 5 users at one time, it offers 7 different exercise stations.

Stations: Sit-up, leg lift, seated knee raise/plank/push-up, 4 lower sit-up stations.

Size: 84" long x 25" wide x 24" high.
Weight 260 pounds.

**FITNESS EQUIPMENT**

Extreme Bench - 10 Stations & Activities

The SuperMAX 10 Station Extreme is the heaviest, strongest, and most versatile fitness bench made. Weighing over 300 pounds and able to accommodate 7 users at one time, it offers 10 different exercise stations. The SuperMAX Extreme is designed to provide a complete workout, shoulders, chest, triceps, abs, arms, legs and more.

Stations: Sit-up, leg lift, seated knee raise/plank/push-up, triceps dip/angle push-up, squat/lower pull-up, reverse push-up, 4 lower sit-up stations.

Size: 115" long x 25" wide x 24" high. Weight 305 pounds.





Doggie Playsystems

Dog parks are rapidly becoming the most popular type of park in the USA! There are more than 70–80 million dogs in this country and nearly 45% of families have one or more dogs. This makes dog parks the perfect place for families and their dogs to get together to exercise and to socialize.

Dog parks help bring communities together! More and more communities are becoming pet friendly by building attractive and fun places where families and their pets can exercise and socialize in a healthy outdoor environment promoting confidence and healthy play for their dogs and the owners.

Doggie Playsystems dog park equipment design is based on agility components that promote climbing, crawling, weaving, jumping, as well as bonding between dogs and their owners. Doggie Playsystems products are functional, durable, heavy-duty and made to last a lifetime.

Create a simple dog park play area by combining a few pieces or go with a complete, full-blown turnkey dog park by incorporating all of the available activities. Doggie Playsystems has the equipment to fit most any requirement and budget. All Doggie Playsystems equipment is designed to be sturdy, fun and challenging for all breeds, abilities, sizes and confidence levels.



DE-3045
Tunnel Time

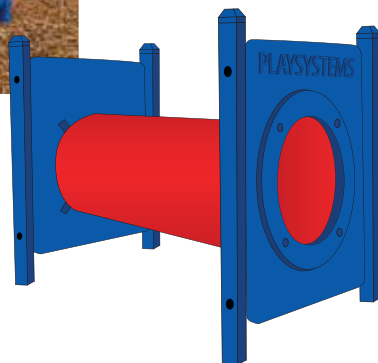

DE-3049
Triple Loop Jump

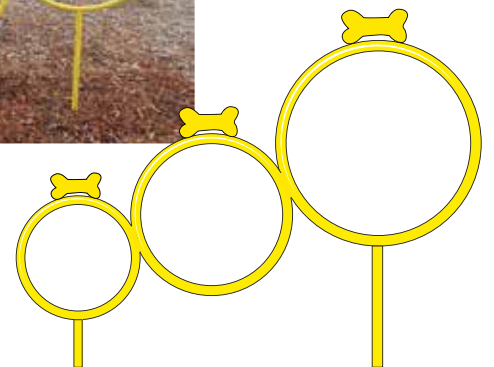



DE-3053
A-Frame Climber

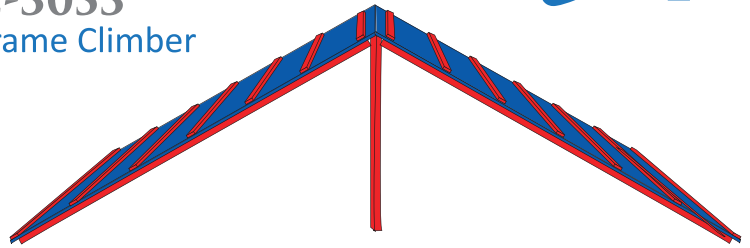

DE-3057
Jump Bars



DE-3061
Teeter Totter

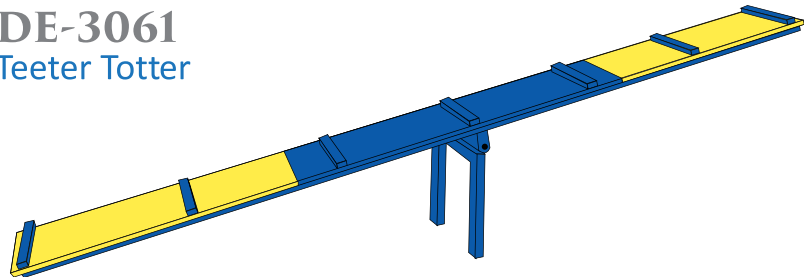

DE-3065
Open Tunnel



DE-3069
Jumping Pads

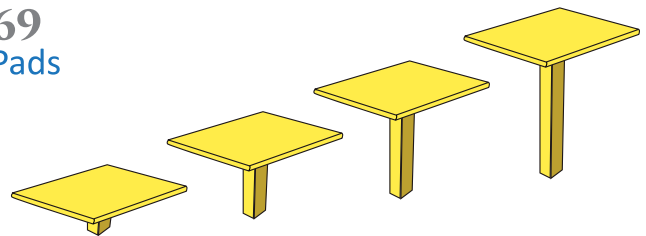

DE-3073
Dog Walk

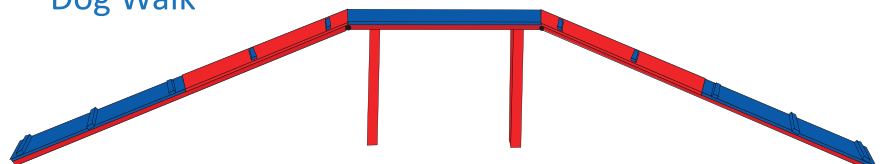



DE-3077
Hoops

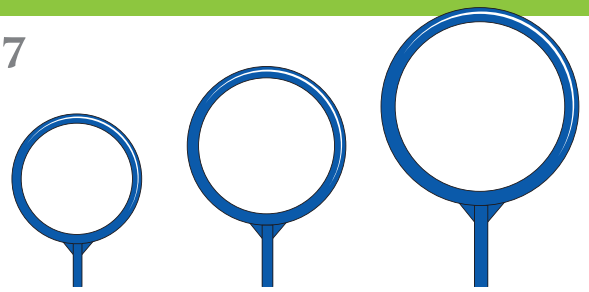

DE-3081
Weaving Poles

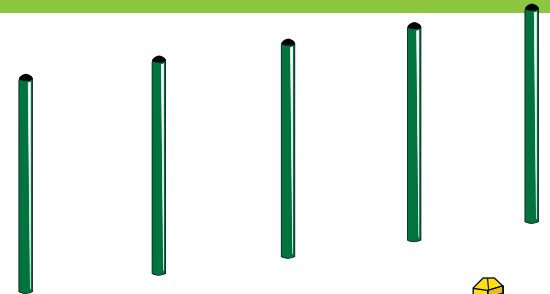

DE-3085
Adjustable Jump

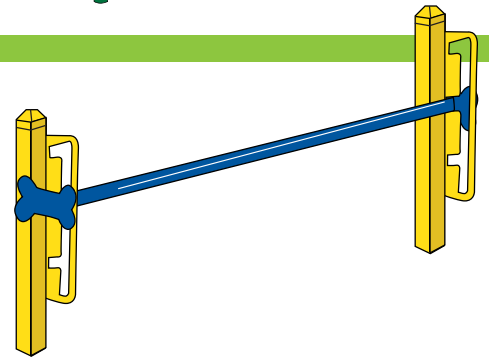

Doggie Playsystems dog park equipment is designed and engineered to withstand just about every kind of use thrown at it. Since dog parks are usually open to the public, it is very important that the equipment is both strong and durable. The rigid standards applied to the design and manufacturing of Doggie Playsystems equipment are second to none. Not only is it the heaviest duty equipment on the market, it is also the most modular. Doggie Playsystems dog park pieces can be designed to fit into almost any location.

The perfect places for Dog Parks:

- Apartments and condominiums
- Community parks and homeowner associations
- Retirement communities
- City, county and state parks
- Open spaces
- Recreation centers
- Anywhere people and their dogs gather



DE-3170
Hitching Post



DE-3180
Doggie Pot



DE-3150
Leash Post

Color Choices:

The standard colors are green, red, blue and yellow.



With over 35 years of experience manufacturing commercial playground equipment, site furnishings and outdoor fitness equipment Pacific Outdoor Products has designed Doggie Playsystems, a heavy duty state of the art line of recreational dog park equipment. All equipment is made in the USA using the highest quality materials, rugged welded construction and powder coated steel resulting in a product that will perform for years to come!



Park Rules Sign
DE-3190

GROUND LEVEL ADA ACTIVITIES



Window Panel



Ball Toss



Steering Wheel



Peek-a-Boo Panel



Activity Panel



Store Front



PE-7896

 **PACIFIC OUTDOOR**
PRODUCTS, INC.

PROUDLY MADE IN THE U.S.A.
MAPLE VALLEY, WA
425-432-6000



For more safety information contact the Consumer Product Safety Commission (CPSC) at 800-638-8270 or American Society for Testing and Materials (ASTM) at 610-832-9500.